

# BlueShadow

## Detector 50D

### Instructions



Document no. V7659

# HPLC



**Note:** For your own safety, read the instructions and follow the warnings and safety information on the device and in the instructions. Keep the instructions for future reference.



**Note:** In case you require this instruction in another language, please submit your request including the corresponding document number via e-mail or fax to KNAUER.

**Support:** Do you have questions about the installation or the operation of your instrument or software?

**International Support:**

Contact your local KNAUER partner for support:

[www.knauer.net/en/Support/Distributors-worldwide](http://www.knauer.net/en/Support/Distributors-worldwide)

**Support in Germany**

(Austria & Switzerland on case-to-case basis):

Phone: +49 30 809727-111 (workdays 9-17h CET)

Fax : +49 30 8015010

E-mail: [support@knauer.net](mailto:support@knauer.net)

**Publisher:** KNAUER Wissenschaftliche Geräte GmbH

Hegauer Weg 38

14163 Berlin

Germany

Phone: +49 30 809727-0

Fax: +49 30 8015010

Internet: [www.knauer.net](http://www.knauer.net)

E-mail: [info@knauer.net](mailto:info@knauer.net)

**Version information:** Document number: V7659

Version number: 1.2

Release date: May 10, 2023

Translation of the original edition

This instruction applies to products with the product number: E652XYZZ

The information in this document is subject to change without prior notice. For the latest version of the instructions, visit our website: [www.knauer.net/library](http://www.knauer.net/library).



**Copyright:** This document contains confidential information and may not be reproduced without written consent of KNAUER Wissenschaftliche Geräte GmbH.

© KNAUER Wissenschaftliche Geräte GmbH 2023  
All rights reserved.

---

# Table of Contents

<b>1. General</b>	<b>3</b>
1.1 About these instructions	3
1.2 Signal words	3
1.3 Additional typographical conventions	3
1.4 Legal information	4
1.4.1 Liability limitation	4
1.4.2 Transport damage	4
1.4.3 Warranty conditions	4
1.4.4 Declaration of conformity	4
<b>2. Basic safety instructions</b>	<b>5</b>
2.1 Intended use	5
2.1.1 Operating ranges	5
2.1.2 Foreseeable misuse	5
2.2 User qualification	5
2.3 Operator responsibility	6
2.4 Personal safety equipment	6
2.5 Working with solvents	7
2.5.1 General requirements	7
2.5.2 Contamination by health-threatening solvents	7
2.5.3 Avoiding leakage	7
2.6 Specific environments	8
2.6.1 Earthquake-endangered areas	8
2.6.2 Explosive environment	8
2.6.3 Cooling room	8
2.6.4 Wet room	8
2.7 Maintenance, care and repair	8
2.8 Service request form and decontamination report	9
<b>3. Product information</b>	<b>10</b>
3.1 Features	10
3.2 Scope of delivery	11
3.3 Views	11
3.3.1 Front view	11
3.3.2 Rear view	12
3.4 Symbols and signs	12

---

<b>4. Installation and initial startup</b> .....	<b>13</b>
4.1 Unpacking .....	13
4.2 Ambient conditions .....	13
4.2.1 Operation site .....	13
4.2.2 Ambient temperature .....	13
4.2.3 Space requirements .....	14
4.3 Power supply .....	14
4.4 Inserting the flow cell .....	15
4.4.1 Changing the optical path length of the preparative flow cell .....	16
4.5 Connecting capillaries .....	18
4.6 Computer control .....	19
4.6.1 Setting up LAN .....	19
4.6.2 Configuring LAN settings .....	20
4.6.3 Connecting devices with LAN .....	20
4.6.4 Configuring the router .....	21
4.6.5 Integrating LAN into the company network .....	21
4.6.6 Controlling several systems separately in LAN .....	22
4.7 Remote control .....	23
4.7.1 Connector assignment .....	23
4.7.2 Connecting the pin header .....	25
4.8 Analog control .....	26
4.9 Integrator Port .....	26
4.10 Switching on .....	26
<b>5. Operation</b> .....	<b>27</b>
5.1 Initial operation .....	27
5.2 Software control .....	27
5.2.1 Switching the detector on .....	27
5.2.2 Controlling with display and keypad .....	27
5.2.3 LED status .....	28
5.2.4 Operating with the keypad .....	28
5.2.5 Switch-on and self-test .....	29
5.3 Selecting a wavelength .....	30
5.3.1 Options for signal output .....	30
5.4 Menu structure .....	31
5.4.1 Main menu .....	31
5.4.2 Menu structure: overview .....	32
5.4.3 Device setting parameters .....	33
5.5 GLP menu .....	37
5.6 Program menu .....	38

---

---

5.6.1	Creating a program . . . . .	39
5.6.2	Running a program . . . . .	40
5.6.3	Changing a program. . . . .	41
5.6.4	Deleting a program line . . . . .	41
5.6.5	Deleting a program. . . . .	41
5.6.6	Creating and running a program with preselectable start time (Wake-Up Program). . . . .	42
5.7	Device Links . . . . .	43
5.7.1	Creating a Link . . . . .	44
5.7.2	Running a Link . . . . .	45
5.7.3	Changing a Link. . . . .	46
5.7.4	Deleting link lines . . . . .	46
5.7.5	Deleting a Link. . . . .	46
5.8	Scan menu. . . . .	47
5.8.1	Autozero scan. . . . .	47
5.8.2	Wavelength scan . . . . .	47
<b>6.</b>	<b>Functionality tests . . . . .</b>	<b>48</b>
6.1	Installation Qualification (IQ) . . . . .	48
6.2	Operation Qualification (OQ) . . . . .	48
<b>7.</b>	<b>Troubleshooting. . . . .</b>	<b>49</b>
7.1	LAN. . . . .	49
7.2	Possible problems and solutions. . . . .	50
7.3	System messages. . . . .	51
<b>8.</b>	<b>Maintenance and care . . . . .</b>	<b>54</b>
8.1	Maintenance contract . . . . .	54
8.2	Cleaning and caring for the device. . . . .	55
8.3	Cleaning the flow cell . . . . .	55
8.3.1	Rinsing the flow cell. . . . .	55
8.3.2	Cleaning the lens of an analytical flow cell . . . . .	56
8.3.3	Cleaning the light guide of a preparative flow cell . . . . .	57
8.4	Replacing the flow cell . . . . .	59
<b>9.</b>	<b>Transport and storage. . . . .</b>	<b>60</b>
9.1	Taking the device out of operation. . . . .	60
9.2	Packing the device. . . . .	60
9.3	Transporting the device . . . . .	60
9.4	Storing the device . . . . .	60

---

<b>10. Disposal</b> .....	<b>61</b>
10.1 AVV-Marking Germany.....	61
10.2 WEEE registration number.....	61
10.3 Eluents and other operating materials.....	61
<b>11. Technical data</b> .....	<b>62</b>
11.1 Main features.....	62
11.2 Communication.....	62
11.3 General.....	63
<b>12. Chemical compatibility of wetted materials</b> .....	<b>64</b>
12.1 General.....	64
12.2 Plastics.....	64
Polyetheretherketone (PEEK).....	64
Polyethylene terephthalate (PET, outdated PETP).....	64
Polyimide (Vespel®).....	65
Ethylene-tetrafluorethylene copolymer (ETFC, Tefzel®).....	65
Perfluorethylenpropylen-Copolymer (FEP), Perfluoralkoxy-Polymer (PFA).....	65
Polyoxymethylene (POM, POM-H-TF).....	65
Polyphenylene sulfide (PPS).....	65
Polytetrafluorethylene (PTFE, Teflon®).....	65
Systec AF™.....	65
Polychlortrifluorethylene (PCTFE, Kel-F®).....	66
Fluorinated rubber (FKM).....	66
Perfluorinated rubber (FFKM).....	66
12.3 Non-metals.....	66
Diamond-like carbon (DLC).....	66
Ceramic.....	66
Alumina (Al <sub>2</sub> O <sub>3</sub> ).....	66
Zirconium oxide (ZrO <sub>2</sub> ).....	66
Sapphire.....	66
Ruby.....	66
Mineral wool.....	67
Glass, glass fibre, quartz, quartz glass.....	67
12.4 Metals.....	67
Stainless steel.....	67
Hastelloy®-C.....	67
Titanium, titanium alloy (TiAl <sub>6</sub> V <sub>4</sub> ).....	67

# 1. General

## 1.1 About these instructions

These operating instructions enable the safe and efficient operation of the device. The user must have carefully read and understood these operating instructions before starting any work.





The basic prerequisite for safe operation is compliance with all safety instructions (see „2 Basic safety instructions“, p. 7). In addition to the safety and warning instructions in these operating instructions, the local accident prevention regulations and the national industrial safety regulations apply.

These operating instructions are an integral part of the device. It must be kept in the immediate vicinity of the device and accessible to the user at all times.

You can download these and other instructions from the KNAUER website: [www.knauer.net/library](http://www.knauer.net/library).

## 1.2 Signal words

Possible dangers related to the device are distinguished in personal and material damages.

Symbol	Meaning
	DANGER (red) indicates a highly hazardous situation. If not avoided, it will result in death or serious injury.
	WARNING (orange) indicates a hazardous situation. If not avoided, it could result in death or serious injury.
	CAUTION (yellow) indicates a moderate hazardous situation. If not avoided, it could result in minor or moderate injury.
	NOTICE (blue) is used to address issues which are not related to physical injury.

## 1.3 Additional typographical conventions

- General equal treatment: When persons are described, this document uses the male grammar form to keep the text easy to read. The form has a neutral sense and speaks to people of any gender in the same way.
- Note: Specific information are prefixed with the word "Note" and an information icon.

 **Note:** This is an example.

## 1.4 Legal information

### 1.4.1 Liability limitation

The manufacturer is not liable for the following issues:

- Non-compliance of these instructions
- Non-observance of necessary safety precautions
- Improper use
- Operation of the device by unqualified personnel (see „2.2 User qualification“, p. 7)
- Use of non-approved spare parts
- Technical changes by the user such as opening the device and unauthorized modifications
- Violations of General Terms and Conditions (GTC)

### 1.4.2 Transport damage

The packaging of our devices provides the best possible protection against transport damage. However, check the packaging for transport damage. In case you notice any damage, inform the Technical Support and the shipping company within three workdays.

### 1.4.3 Warranty conditions

For information on warranty please refer to our general terms and conditions on the website: [www.knauer.net/terms](http://www.knauer.net/terms)

### 1.4.4 Declaration of conformity

The declaration of conformity is enclosed as a separate document with the product and can be obtained online:

[www.knauer.net/en/Support/Declarations-of-conformity](http://www.knauer.net/en/Support/Declarations-of-conformity)



## 2. Basic safety instructions

The device has been developed and constructed in such a way that hazards arising from its intended use are largely excluded. Nevertheless, the following safety instructions must be observed in order to exclude residual hazards.

### 2.1 Intended use

Only use the device for applications that fall within the range of the intended use. Otherwise, the protective and safety equipment of the device could fail.

#### 2.1.1 Operating ranges

The device is intended to be used for chromatographic applications in the laboratory.

#### 2.1.2 Foreseeable misuse

Refrain from the use of the device for the following purposes or conditions:

- Medical purposes. The device is not approved as a medical product.
- Operating outside of a laboratory or measurement room. Otherwise, the manufacturer does not guarantee the functionality and safety of the device.
- Operation in potentially explosive areas without special and additional explosion protection. Contact the KNAUER Customer Support for more information.

### 2.2 User qualification

The users are qualified to handle the device if all of the following points apply:

- They have at least a basic knowledge of liquid chromatography.
- They have knowledge about the properties of the used solvents and their health risks.
- They are trained for the special tasks and activities in the laboratory and know the relevant standards and regulations.
- Due to their technical training and experience, they can understand and carry out all the work described in the operating instructions on the instrument and recognize and avoid possible dangers independently.
- Their ability to react is not impaired by the consumption of drugs, alcohol or medication.
- They have participated in the installation of an instrument or training by KNAUER or an authorized company.

If users do not meet these qualifications, they must inform their supervisors.

## 2.3 Operator responsibility

The operator is any person who operates the device himself or leaves it to a third party for use and who bears the legal product responsibility for the protection of the user or third parties during operation.

The obligations of the operator are listed below:

- Know and follow the applicable work safety regulations
- Identify hazards arising from the working conditions at the place of use in a risk assessment.
- Set up operating instructions for the operation of the device.
- Regularly check whether the operating instructions correspond to the current status of the regulations.
- Clearly regulate and specify responsibilities for installation, operation, troubleshooting, maintenance and cleaning and set clear rules
- Ensure that all personnel who work with the device have read and understood these operating instructions
- Train the personnel who work with the device at regular intervals and inform them about the dangers.
- Provide the necessary safety equipment to the employees working with the unit (see section below).

## 2.4 Personal safety equipment

The protective measures required in the laboratory must be observed and the following protective clothing worn during all work on the device:

- Safety glasses with side protection
- Protective gloves in accordance with the prevailing ambient conditions and used solvents (e.g. heat, cold, protection against chemicals)
- Lab coat
- Personalised protective safety equipment which is specified in the particular laboratory

## 2.5 Working with solvents

### 2.5.1 General requirements

- The user is trained for handling different solvents.
- Note recommended solvents and concentrations in these instructions in order to avoid personal injury or damage to the device. For example, certain chemicals may cause PEEK capillaries to swell or burst (see „12 Chemical compatibility of wetted materials“, p. 67).
- Note that organic solvents are toxic above a certain concentration. For handling hazardous solvents see next section.
- Mobile phases and samples may contain volatile or combustible solvents. Avoid the accumulation of these substances. Ensure good ventilation of the installation site. Avoid open flames and sparks. Do not operate the instrument in the presence of flammable gases or vapors.
- Only use solvents which do not self-ignite under given conditions. This applies especially to the use of a thermostat where liquids could get onto hot surfaces in the interior.
- Degas solvents before use and observe their purity.

### 2.5.2 Contamination by health-threatening solvents

- Contamination with toxic, infectious or radioactive substances poses a hazard for all persons involved during operation, repair, sale, and disposal of a device.
- All contaminated devices must be properly decontaminated by a specialist company or the operating company before they can be recommissioned, repaired, sold, or disposed (see „10 Disposal“, p. 64).

### 2.5.3 Avoiding leakage

Risk of electrical shock or short circuit if solvents or other liquids leak into the interior of the device. You can avoid a leakage through the following measures:

- Tightness: Visually check the device or system regularly for leaks.
- Solvent tray: The use of a solvent tray prevents liquids get from the bottles into the inside of the device.
- Eluent lines: Install capillaries and hoses in such a way that, in case of a leak, liquids cannot get into the interior of the devices underneath.
- In case of leakage: Switch off the system. Only take the device into operation if the cause of the leak has been resolved (see „8 Maintenance and care“, p. 57).

## 2.6 Specific environments

### 2.6.1 Earthquake-endangered areas

In earthquake-endangered areas, do not stack more than 3 devices on top of each other. Otherwise there is risk of injury due to falling devices or loose parts.

### 2.6.2 Explosive environment

Never use the system in potentially explosive atmospheres without appropriate protective equipment. For more information, contact the KNAUER Customer Support.

### 2.6.3 Cooling room

You may operate the device in a cooling room. To prevent condensation, note the following instructions:

- Allow the device to acclimatize for min. 3 hours before taking it into operation.
- After taking into operation, the device should stay switched on.
- Avoid temperature fluctuations.

### 2.6.4 Wet room

The device must not be operated in wet rooms.

## 2.7 Maintenance, care and repair

- Avoiding electric shock: Before performing any maintenance and service work, disconnect the device from the power supply.
- Tools: Use only tools recommended or prescribed by the manufacturer.
- Spare parts and accessories: Only use original parts and accessories made by KNAUER or a company authorized by KNAUER.
- PEEK fittings: Use PEEK fittings only for a single port or brand-new PEEK fittings in order to avoid dead volume or not exactly fitting connections.
- Column care: Follow KNAUER or other manufacturer's instructions on caring for the columns (see [www.knauer.net/columncare](http://www.knauer.net/columncare)).
- Used capillaries: Do not use any used capillaries elsewhere in the system in order to avoid dead volumes, not exactly fitting connections and spreading contamination.
- Safety features: The device may only be opened by the KNAUER Customer Support of KNAUER or any company authorized by KNAUER (see „1.4.1 Liability limitation“, p. 6).
- For more information visit the KNAUER website: [www.knauer.net/hplc-troubleshooting](http://www.knauer.net/hplc-troubleshooting).

---

## 2.8 Service request form and decontamination report

Devices which are shipped without the completed document "Service request form and decontamination report" will not be repaired. If you would like to return a device to KNAUER, make sure to enclose the completed document: [www.knauer.net/servicerequest](http://www.knauer.net/servicerequest).

## 3. Product information

### 3.1 Features

The detector is a measuring system for fast and precise measurement in the UV range and, with a halogen lamp (optional), also in the visible range. The measurement principle is based on the attenuation of a monochromatic light beam passing through liquid.

**Self-calibration** The self-calibration of the detector guarantees operation without external settings. Type and combination of the installed lamps as well as the transmission of the corresponding installed flow cell are analyzed and used for the automatic setting of the integration time, in order to achieve a high level of sensitivity.

- Features**
- Signal linearity and wavelength accuracy are verified by independent measurements as part of a self-calibration.
  - The use of light sources for a specific spectral range is possible (UV: Deuterium lamp, VIS: Halogen lamp). A tandem operation with both light sources is also possible, allowing a wavelength range of 190 - 900 nm (UV/VIS) and a wavelength range of 190 - 750 nm (UV) to be covered without changing the lamp.
  - Within a system, it is possible to measure four wavelengths simultaneously with the help of the software control.
  - Recording of a spectrum of 100 nm width in less than 100 ms.
  - The beam guidance is designed so that no chromatic aberration occurs and thus the best possible useful signal is available, independent of the selected wavelength.
  - Automatic recording and storage of the device-specific characteristics that are important for GLP (Good Laboratory Practice) and OQ (Operation Qualification) or for the device service and device history. These are operating times, operating parameters, wavelength accuracy and reference spectra.
  - Self-running and up-to-date device status diagnostics.
  - Control with HPLC software possible.
  - Easy integration of the detector into complex chromatography systems.
  - Extremely low noise level and baseline drift.
  - High data rates for fast chromatography.
  - Flexible options for use in the entire field of LC applications due to a comprehensive range of flow cells for the detectors, from nano HPLC cells with flow rates  $\approx$  100 nl/min to preparative flow cells with 10 l/min.

## 3.2 Scope of delivery

The following items should be included in the scope of delivery:

- BlueShadow Detector 50D with test cell
- BlueShadow Detector 50D accessory kit
- Power cable
- Transport protection

Valid documents:

- BlueShadow Detector 50D Instructions V7659
- Declaration of Conformity

## 3.3 Views

### 3.3.1 Front view

The display with the corresponding keypad, the LED light for standby mode, and the flow cell can be found on the detector's front side.

#### Legend

- ① Status LED
- ② Display
- ③ Flow cell with holder

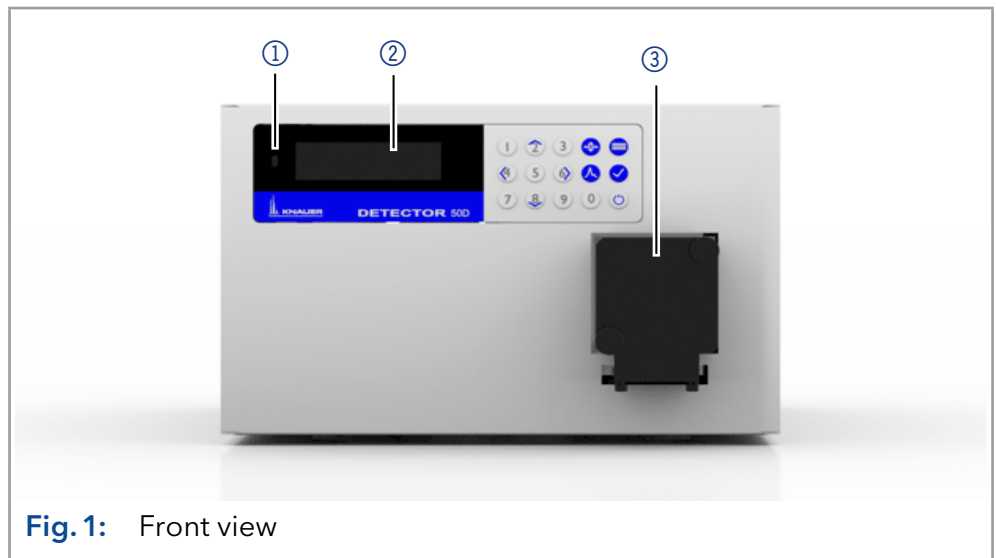

**Fig. 1:** Front view

### 3.3.2 Rear view

The rear of the device contains the mains power connection, power switch, connections for external devices, technical symbols and serial number, among other things.

#### Legend

- ① Serial number
- ② Fan opening
- ③ Power switch
- ④ Power connection
- ⑤ Pin header
- ⑥ RS-232 port
- ⑦ LAN connector
- ⑧ Integrator output

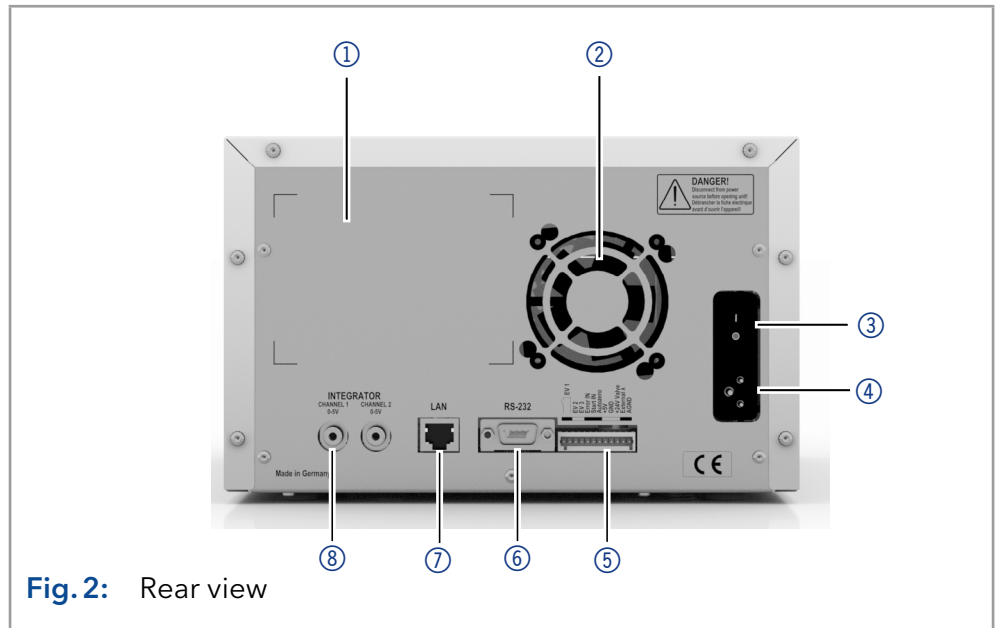

Fig. 2: Rear view

### 3.4 Symbols and signs

The following symbols and signs can be found on the device:

Symbol	Meaning
	High-voltage hazard
	Electrostatic discharge hazard, damages to system, device, or components can occur.
	A device marked with CE fulfills the product specific requirements of European directives. This is confirmed in a Declaration of Conformity.
	Testing seals in Canada and the USA at nationally recognized testing centers (NRTL). The certified device or system has successfully passed the quality and security tests.
	The device complies with the product-specific requirements of the United Kingdom.



## 4. Installation and initial startup

Before you determine the operation site, read the chapter „11. Technical data“ on page 65. There you will find all device-specific information on power supply, ambient conditions and humidity.



**Note:** The intended use be ensured only if the requirements for ambient conditions of the operating environment are met.

### 4.1 Unpacking

#### Process

- Procedure**
1. Place the packaging in such a way that the lettering on the label is in the correct position.
  2. Check the packaging, the device and the accessories for transport damage.
  3. Check the scope of delivery. In the event of incomplete delivery, contact technical support immediately.
  4. When lifting, carrying or moving the device, grab the device only from below on the sides.

- Next steps**
- Keep the included packing list for repeat orders.
  - Keep the original packaging for safe storage or transportation.

### 4.2 Ambient conditions

#### 4.2.1 Operation site

Observe the following requirements for the operation site so that the measurement results are not influenced:

- Place on a firm, level and straight surface.
- Protect against direct sunlight.
- Do not expose to air drafts such as air conditioning systems.
- Do not set up the to other machines that cause floor vibrations.
- Keep from high frequency sources.
- Ensure adequate ventilation (see „4.2.3 Space requirements“, p. 16).
- Avoid temperature fluctuations (see „4.2.2 Ambient temperature“, p. 15).

#### 4.2.2 Ambient temperature

If the ambient temperature of the device is abruptly changed (e.g. when it is installed in a cooling chamber), condensation will form inside the device and may cause damage to the device. Allow the device to acclimate for 3 h, before it is connected to the power supply and taken into operation.

### 4.2.3 Space requirements

- Make sure that the power plug on the power supply (wall socket or power strip) is always accessible, so that the device can be disconnected from the power supply.
- Ensure adequate ventilation around the device, otherwise it may overheat and malfunction:
  - Min. 5 cm distance if another device is set on one side.
  - Min. 10 cm distance if further devices are set on both sides.
  - At least 15 cm to the cooler fan on the rear.

## 4.3 Power supply

### Power supply requirements

- Failure-free power supply: For failure-free operation, the electrical voltage must be free of fluctuations, residual currents, voltage peaks and electromagnetic interference. The device must receive sufficient voltage and reserve capacity.
- Check voltage: Only connect devices to a power supply whose voltage corresponds to the permissible voltage of the device.
- Power consumption: The nominal power of the connected devices must not exceed 50 % of the highest connected power capacity, since higher currents can flow briefly when the device is switched on.
- Main connection: The electrical power supply at the operation site must be connected directly to the nearest main power connection.
- Grounding: The connectors for the voltage must be grounded accordingly.

### Power supply cables and plugs

- Original parts: For power supply, use the supplied power cable and plug to meet the specifications which are described in chapter „11. Technical data“ on page 65. Detachable power cables are not allowed to be replaced with other cable types.
- Country-specific plugs: Before switching on the device, check whether the supplied plug is approved for your country. Overview of the device- and country-specific plug types from KNAUER: [www.knauer.net/plugs](http://www.knauer.net/plugs).
- Power strips: If several devices are connected to one power strip, always consider the maximum power consumption of each device.
- Access to power supply: Make sure that the power plug on the power supply (wall socket or power strip) is always accessible, so that the device can be disconnected easily from the power supply.
- Damaged power supply cables and plugs: For safety reasons, damaged or faulty cables and plugs must not be used to connect the device to the power supply. Replace defective cables and plugs only with KNAUER accessories.

## 4.4 Inserting the flow cell

The supply configuration of this detector only includes a test cell (dummy cell), which does not have connections for solvent. It is used, for example, to check the lamp intensity, as a dirty flow cell could distort this value. Before using the device with solvents, the test cell must, therefore, be removed, and a flow cell must be installed.

- Prerequisites**
- The optical path length has been set (optional for special flow cells).
  - The device has been switched off.
  - The power supply has been disconnected.

### Procedure

#### Process

1. Unscrew the knurled-head screws ③ of the cover plate ④. Hold the flow cell securely with your hand during this procedure.
2. Pull out the slide with the flow cell ⑤ towards the front.
3. Remove the flow cell upward.
4. Position the new flow cell on top of the slide. Keep holding the flow cell. Because of the small, drilled hole on the flow cell (see figure 4), the cell fits to the detector only when oriented correctly.
5. Push the slide back into the detector.
6. Screw the knurled-head screws back into the cover plate ④ and tighten.
7. Connect the incoming and outgoing capillaries at the inlet ① and outlet ② of the measuring cell.

#### Figure

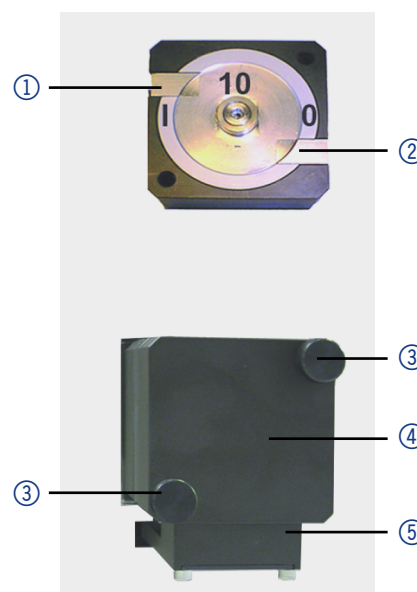

**Fig. 3** Inserting the flow cell

**Next step** Connect the capillaries.

### 4.4.1 Changing the optical path length of the preparative flow cell

At delivery, the optical path length of a preparative flow cell is set to 2 mm at the factory. To reduce it to 1.25 or 0.5 mm, proceed as follows.

This description applies to preparative flow cells with 1/8" or 1/4" connections.

#### Procedure

#### Process

1. Remove the threaded ring ① using a hexagonal spanner.
2. Remove stainless steel cover ② and the PEEK spacer ③.
3. Insert the stainless steel cover again and carefully tighten the threaded ring again.
4. The missing spacer causes the light guide ④ to be pushed deeper into the flow cell (0.75 mm), resulting in a shortened optical path length of 1.25 mm. To further shorten down to 0.5 mm, the PEEK spacer on the other cell side must also be removed.

#### Figure

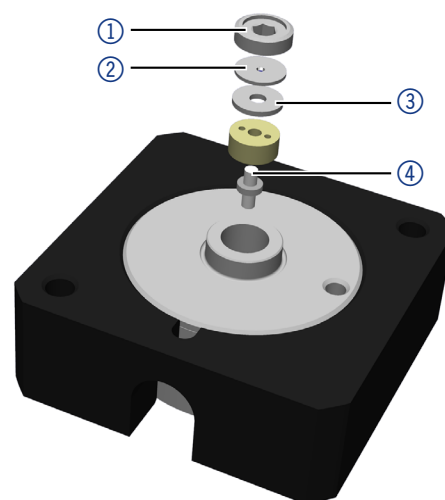

**Fig. 4** Shortening the optical path length

To extend the optical path length in steps of 0.75 mm, put the spacers back in. Proceed as follows:

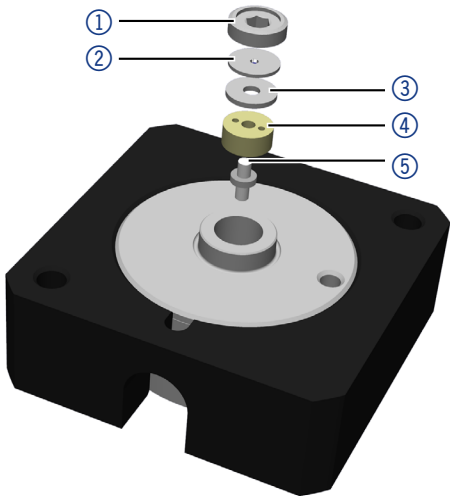
Procedure	Process	Figure
	<ol style="list-style-type: none"><li>1. Remove the threaded ring ① using a hexagonal spanner.</li><li>2. Remove the stainless steel cover ② and light guide ⑤, together with the pressure bushing ④, with tweezers.</li><li>3. To extend the path length, push the light guide out about 1 mm. Please use a clean cloth and avoid touching the light guide with your fingers.</li><li>4. Push the light guide together with the pressure bushing back into the cell.</li><li>5. Insert the PEEK spacer ③ followed by the stainless steel cover.</li><li>6. Carefully tighten the threaded ring again.</li><li>7. When tightening the threaded ring, the rod-shaped light guide is pushed into the correct position in the cell. Inserting a spacer extends the optical path length by 0.75 mm. The PTFE seal does not need to be replaced when the path length is changed.</li></ol>	 <p>The diagram shows an exploded view of the flow cell assembly. A black base is shown with a central circular opening. Above it, a stainless steel cover (2) is shown with a light guide (5) and a pressure bushing (4) attached. A PEEK spacer (3) is shown being inserted between the stainless steel cover and the light guide. A threaded ring (1) is shown being tightened onto the top of the stainless steel cover. The callouts are: 1. Threaded ring, 2. Stainless steel cover, 3. PEEK spacer, 4. Pressure bushing, 5. Light guide.</p>

**Fig. 5:** Extending the Optical Path Length

**Next step** Insert the flow cell into the detector.

## 4.5 Connecting capillaries

Capillaries connect the detector to other devices and lead liquids.

**Prerequisite** Flow cell has been assembled.

**Tools** Torque wrench

### NOTICE

#### Component defect

Damage to components due to excessive tightening possible.  
Observe the torque of the screw connection.

→ Use 5 Nm torque for stainless steel fittings.

→ Use 1 Nm torque for PEEK fittings.



**Note:** PEEK fittings withstand a maximum pressure of 400 bar.

### Procedure

#### Process

1. Push the capillary ② through the fitting ①.
2. Push the clamping ring ③ onto capillary.

#### Figure

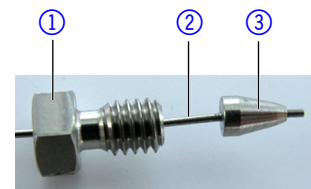

**Fig. 6** Capillary fitting

3. Manually, screw together the capillary ⑤ and the flow cell ④. Tighten the fitting with the wrench.

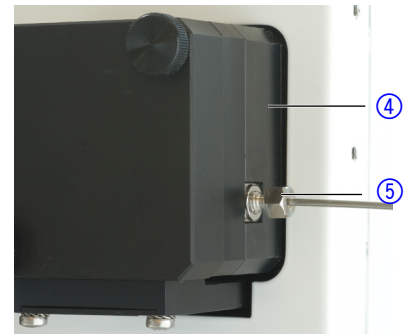

**Fig. 7** Capillary and flow cell

**Result** Capillaries have been connected and the detector is ready for operation.

## 4.6 Computer control

The detector can be operated in different ways:

- Via the pin header
- Via the RS-232 port
- As part of a LAN, via the LAN connector of the router

All connectors for external control are located on the rear side of the detector.

### Legend

- ① Power connection
- ② Pin header
- ③ RS-232 port
- ④ LAN connector
- ⑤ Integrator output

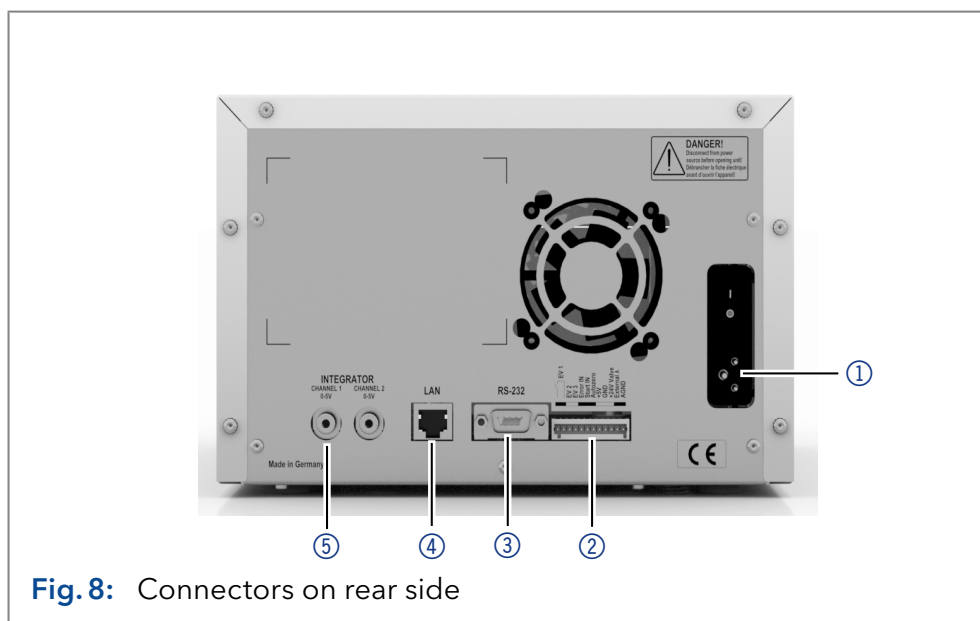

**Fig. 8:** Connectors on rear side



**Note:** HPLC devices from KNAUER only work with IP addresses, which have been assigned by IPv4. IPv6 is not supported.

This chapter describes how to set up a chromatography system in a local area network (LAN) and how a network administrator can integrate this LAN into your company network. The description applies to the operating system Windows® and all conventional routers.

### 4.6.1 Setting up LAN

To set up a LAN, we recommend to use a router. That means the following steps are required:

#### Process

#### Procedure

1. On the computer, go to the control panel and check the LAN properties.
2. Hook up the router to the devices and the computer.
3. Set up the router for the computer network.
4. Install the chromatography software.
5. Switch on the device and run the chromatography software.

**Next steps** Configure LAN properties (see section „4.6.2“).

## 4.6.2 Configuring LAN settings

The LAN uses only one server (which is normally the router) from that the devices automatically receive their IP address.

- Prerequisites**
- In Windows, power saving, hibernation, standby, and screen saver must be deactivated.
  - In case you use an USB-to-COM box, the option "Allow the computer to turn off this device to save power" in the device manager must be deactivated for all USB hosts.
  - Applies to all LAN devices: Disable the setting for the network adapter in Device Manager "Allow the computer to turn off this device to save power".

### Process

- Procedure**
1. In Windows, open <Network and Sharing Center>.
  2. Double-click on <LAN connection>.
  3. Click on the button <Properties>.
  4. Select <Internet Protocol version 4 (TCP/IPv4)>.
  5. Click on the button <Properties>.
  6. Check the settings in the tab <General>. The correct settings for the DHCP client are:
    - a) Obtain an IP address automatically
    - b) Obtain DNS server address automatically
  7. Click on the button <OK>.

**Next steps** Connect devices (see section „4.6.3“).

## 4.6.3 Connecting devices with LAN

A router ② has several LAN ports ③ and one WAN port ④ that can be used to integrate the LAN into a wide area network (WAN), e.g. a company network or the Internet. In contrast, the LAN ports serve to set up a network from devices ① and a computer ⑤. To avoid interference, we recommend operating the chromatography system separately from the company network.



**Note:** You will find patch cables for each device and the router in the accessories kit. To connect the router to a LAN, an additional patch cable is required, which is not supplied within the scope of delivery.

### Legend

- ① Devices
- ② Router
- ③ LAN ports
- ④ WAN/Internet connection
- ⑤ Computer

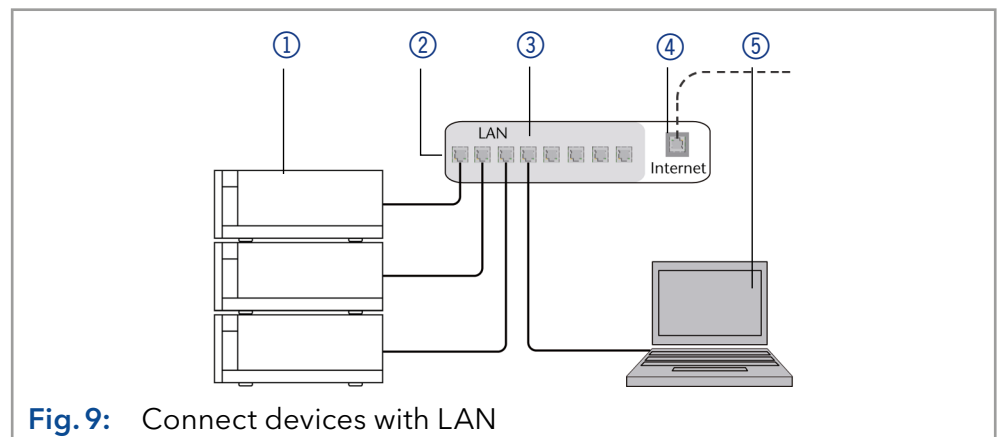



- Prerequisites**
- The computer is switched off.
  - There is a patch cable for each device and the computer.

#### Process

- Procedure**
1. Use the patch cable to connect the router and the computer. Repeat this step to connect all devices.
  2. With additional patch cables, connect all devices individually with the router.
  3. Use the power supply to connect the router to the mains power system.
- 

**Next steps** Set the router properties (see section „4.6.4“).

### 4.6.4 Configuring the router

The router is preset at the factory. Information about address, user name and password is noted in the router manual: [www.knauer.net/router](http://www.knauer.net/router).

#### Process

- Procedure**
1. To open the router configuration, start your Internet browser and enter the IP address (does not apply for all routers).
  2. Enter user name and password.
  3. Configure the router as DHCP server.
  4. In the router configuration, check the IP address range and make changes if necessary.
- 



**Note:** If the IP address range has been changed, it is essential to note this information on the router.

**Result** Once the router has assigned IP addresses to all devices, the chromatography software can be used to remotely control the system.

### 4.6.5 Integrating LAN into the company network

A network administrator can integrate the LAN into your company network. In this case you use the WAN port of the router.

- Prerequisites**
- There is a patch cable for the connection.

<b>Process</b>	
<b>Procedure</b>	<ol style="list-style-type: none"> <li>1. Make sure that there is no overlap between the IP addresses of the router and the corporate network.</li> <li>2. In case of an overlap, change the IP address range of the router.</li> <li>3. Use the patch cable to connect the router WAN port to the company network.</li> <li>4. Restart all devices, including the computer.</li> </ol>
<b>Result</b>	The LAN is now integrated into the company network.

### 4.6.6 Controlling several systems separately in LAN

Devices connected to a LAN communicate through ports, which are part of the IP address. If more than one chromatography systems are connected to the same LAN and you plan on controlling them separately, you can use different ports to avoid interference. Therefore, the port number for each device must be changed and this same number must be entered into the device configuration of the chromatography software. We recommend to use the same port number for all devices in the same system.



**Note:** The port is set to 10001 at the factory. You have to use the same numbers in the device configuration of the chromatography software as in the device, otherwise the connection fails.

<b>Process</b>	
<b>Procedure</b>	<ol style="list-style-type: none"> <li>1. Find out port number and change it on the device.</li> <li>2. Enter the port number in the chromatography software.</li> </ol>
<b>Result</b>	The connection is established.

## 4.7 Remote control

### 4.7.1 Connector assignment

#### Remote connector

- For receiving start, control, and error signals from external devices
- For sending start, control and error signals to external devices

#### Legend

- ① Integrator output
- ② LAN connector
- ③ Fan opening
- ④ Pin header
- ⑤ RS-232 port

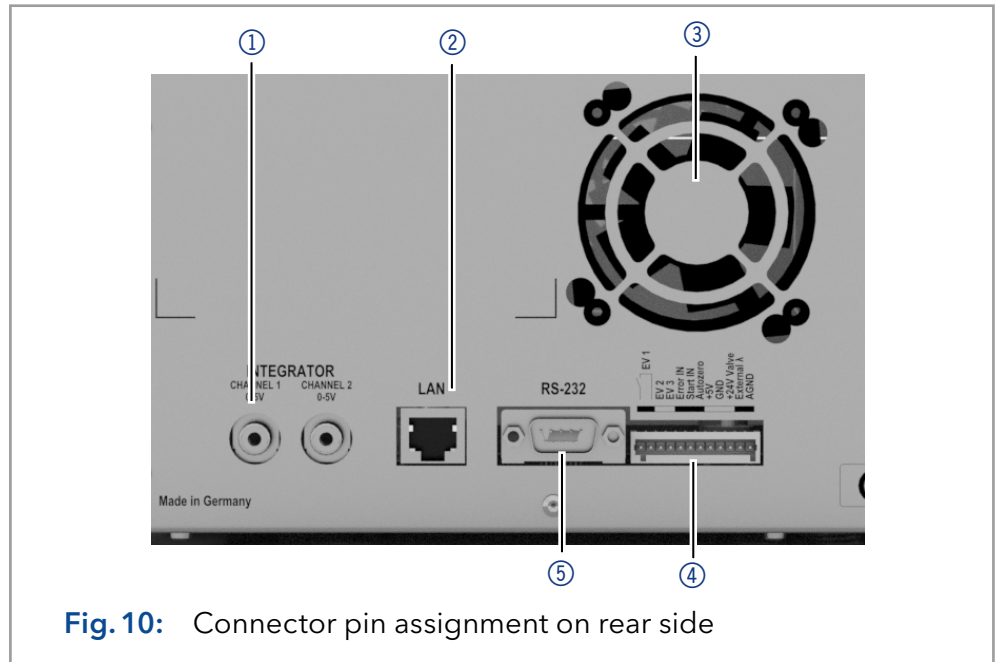





Fig. 10: Connector pin assignment on rear side

Signal	Explanation
EV 1 (Event 1)	<p><b>Relay contact</b></p> <p>Both relay contacts are potential-free (floating). Relay state (open/closed) can be defined by the keypad in stand-alone operation (e.g. as parameter of a program step) or via an external software.</p> <p>Permanent state signal:</p> <ul style="list-style-type: none"> <li>■ EV1-- passive (open relay) 0</li> <li>■ EV1-- active (closed relay) 1</li> </ul> <p>Pulse:</p> <ul style="list-style-type: none"> <li>■ Closed relay contact for at least 1000 ms </li> </ul> <p>Permissible load of the relay contact: 1 A/ 30 V</p>

Signal	Explanation
EV 2 (Event 2)	<p><b>TTL output</b></p> <p>Relay state (open/closed) can be defined by the keypad in stand-alone operation (e.g. as parameter of a program step) or via an external software.</p> <p>Levels:</p> <ul style="list-style-type: none"> <li>▪ low (&lt;0.4 V) 0</li> <li>▪ high (&gt;2.4 V) 1</li> </ul> <p>Pulse:</p> <ul style="list-style-type: none"> <li>▪ High for at least 1000 ms </li> </ul> <p>Load resistance:</p> <ul style="list-style-type: none"> <li>▪ &gt;10 kΩ</li> </ul>
EV 3 (Event 3)	<p><b>TTL output</b></p> <p>Relay state (open/closed) can be defined by the keypad in stand-alone operation (e.g. as parameter of a program step) or via an external software.</p> <p>Levels:</p> <ul style="list-style-type: none"> <li>▪ low (&lt;0.4 V) 0</li> <li>▪ high (&gt;2.4 V) 1</li> </ul> <p>Pulse:</p> <ul style="list-style-type: none"> <li>▪ High for at least 1000 ms </li> </ul> <p>Load resistance:</p> <ul style="list-style-type: none"> <li>▪ &gt;10 kΩ</li> </ul>
Error IN	<p><b>TTL input</b></p> <p>With a high level, running programs are terminated and the message <i>Error input activated</i> appears.</p>
Start IN	<p><b>TTL input</b></p> <p>With a high level, a program is started in hold mode or a link with the corresponding wait parameter is started.</p>
Autozero	Set absorbance values to zero.
GND	Reference (ground) potential for the voltage level of TTL signals.
+5V	Provides a voltage of 5 V with respect to GND. This makes it possible to supply a consumer switched with event EV 1 (relay). The +5V output is protected by a 62 mA fuse.

Signal	Explanation
+24V Valve	<p>Event-controlled switching of 24 V against GND.</p> <ul style="list-style-type: none"> <li>▪ passive 0 V</li> <li>▪ active 24 V</li> <li>▪ 24 V for 1000 ms</li> </ul> <p>Max. current: 24 V-200 mA This output can be used to operate a fraction valve.</p>
External $\lambda$	Allows external analog control of the detector wavelength in single channel mode. The control voltage must be applied against AGND.
AGND	Reference point of the voltage at the input external $\lambda$ .

## 4.7.2 Connecting the pin header

To control one device through another, the pin header is used. To use remote control, you have to connect cables to the pin header. The single ports are used to exchange control signals.

- Prerequisites**
- The device is switched off.
  - The power plug is disconnected from the device.
- Tools**
- Depressor tool

### NOTICE

#### Electronic defect

Connecting cables to the multi-pin connector of a switched on device causes a short circuit.

- Turn off the device before connecting cables.
- Pull the power plug.

### NOTICE

#### Electronic defect

Electrostatic discharge can destroy the electronics.

- Wear a protective bracelet against electrostatic discharge and ground.

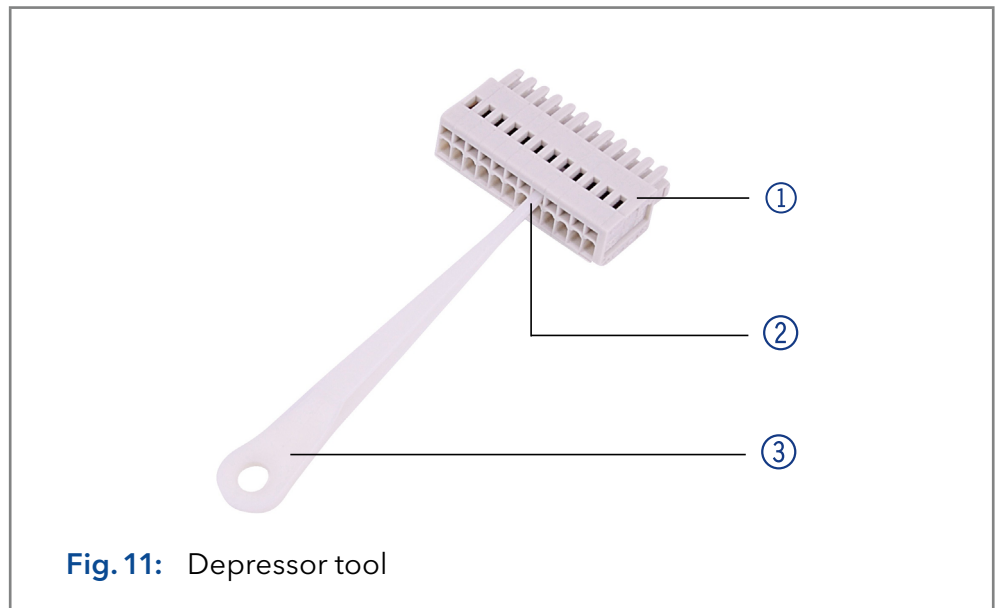

**Fig. 11:** Depressor tool

### Process

1. Insert the depressor tool ③ in an upper small opening at the front of the pin header ①.
2. Insert the cable into the opening ② underneath the inserted depressor tool.
3. Pull out the depressor tool.

**Next steps** Check whether the cables are tightly attached. Press the pin header onto the connector. Finish the installation. Bring the device into operation.

## 4.8 Analog control

Using the analog port, you can control the wavelength by changing the applied voltage. A Control Unit is required in order to select the option *ANALOG* in the *SETUP* menu.

**Example** To use the analog port for controlling the detector, you have to set a zero point and enter a scaling value.

- Zero point at 0 V = 000 nm
- Scaling: 100 nm per Volt

If 5 V voltage is applied, the wavelength is 500 nm.

## 4.9 Integrator Port

The integrator connector sends measuring signals from the detector.

- Non-bipolar
- 1 channel
- 0 to 5 V
- DAC 20 bit
- Scalable
- Offset is adjustable

## 4.10 Switching on

The device is switched on by the power key on the back of the device.

**Prerequisite** ■ Installation has been completed.

### Procedure

#### Process

1. Insert the plug into the male connector ② at the rear panel.
2. Plug the other end into an electric socket.
3. Switch on the device at the power switch ①.

#### Figure

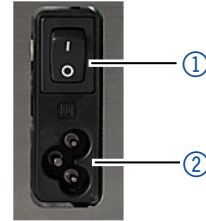

**Fig. 12** Power switch with male connector

## 5. Operation



**Note:** Before the detector is ready for measurements, a flow cell must be installed. You can change the optical path length of a preparative flow cell before assembling the flow cell. The optimal path length depends on type and quantity of the sample.

### 5.1 Initial operation

Use this checklist to check if the detector is ready for initial operation:

- Device is positioned in the correct location.
- The power plug has been connected.

If the device is part of an HPLC system, you should also note the following:

- The network connection to the router is established
- The chromatography software has been installed by KNAUER or a company authorized by KNAUER.
- The capillaries have been connected.

### 5.2 Software control

There are several options for controlling the device:

- With keypad
- With chromatography software

#### 5.2.1 Switching the detector on

The device is switched by the power switch on the back of the device. It begins by initializing the lamps, then proceeds through a self-test and calibration cycle, and finally registers itself as ready to operate with the status *display*.

The detector is now ready to operate.

#### 5.2.2 Controlling with display and keypad

The LC display and the keypad are suitable for the following procedures:

- Monitoring the device functions
- Setting up communication interface
- Using special programs for laboratory work:
  - Setting up analog in- and output (wavelength selection, events, absorbance signal)
  - Program sequences, links and (wake up) events
  - Checking the device and lamp status as part of quality assurance measures in accordance with good laboratory practices (in the *GLP* menu)



**Legend**



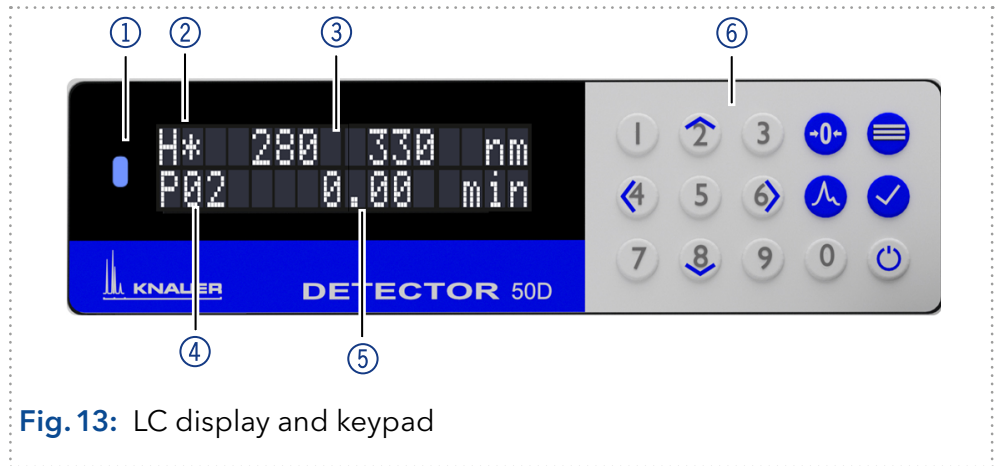

- ① Status LED
- ② Program status
- ③ Wavelengths
- ④ Program number/  
Link number
- ⑤ Program running time
- ⑥ Keypad



**Fig. 13:** LC display and keypad

**5.2.3 Status LED**





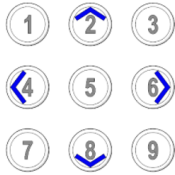

The status of the device is indicated by an LED on the front side. The color of the LED shows the current status.

LED	Status	
	Green	Device is ready (idle status).
	Green flashing	Device is running.
	Yellow	Firmware upload in progress.
	Yellow flashing	Device initialization.
	Red	A serious error occurred.
	Red flashing	An acknowledgeable error occurred.
	Blue	Device in standby.

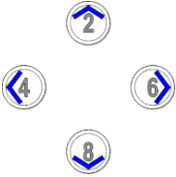
**5.2.4 Operating with the keypad**

The keypad consists of 15 buttons, which allow to operate the device.

Key	Function	Explanation
	Numeric pad	<ul style="list-style-type: none"> <li>■ Activation of numeric pad by pressing the <i>confirmation button</i> at input fields.</li> <li>■ Changing values.</li> </ul>

	Navigation button	<ul style="list-style-type: none"> <li>Navigation through menu with horizontal keys &lt;&gt;.</li> <li>Adjustment of values at input fields with vertical keys ^ v.</li> </ul>
	Autozero button	<ul style="list-style-type: none"> <li>Setting current absorbance values to zero.</li> </ul>
	Menu button	<ul style="list-style-type: none"> <li>Select main menu.</li> <li>Return to one menu further up in the menu structure.</li> </ul>
	Confirmation button	<ul style="list-style-type: none"> <li>Confirm selection.</li> <li>Entering sub menu.</li> <li>Activation of numeric pad usage at input value.</li> </ul>
	Scan menu button	<ul style="list-style-type: none"> <li>Selection of the wavelength range for the scan and the autozero scan.</li> <li>Output of the saved scan data.</li> </ul>
	Standby button	<ul style="list-style-type: none"> <li>Sets device to standby mode.</li> <li>Inserts a decimal point if numeric pad is activated.</li> </ul>





### 5.2.5 Switch-on and self-test

Process	Figure
<ol style="list-style-type: none"> <li>Switch on the detector.</li> <li>After turning the device on, the detector displays the following, consecutive status messages: <ul style="list-style-type: none"> <li>„Initialize“ - self test of electronic components</li> <li>„Lamp heating“ - preheating and ignition of the D2 lamp</li> <li>„Calibrating“ - optical calibration</li> </ul> </li> </ol>	

Process	Figure
<ol style="list-style-type: none"> <li>3. Wait until the detector has completed the calibration.</li> <li>4. After the calibration has been successfully completed, the most recently active program will be displayed.</li> <li>5. The detector is now ready for operation.</li> </ol>	

### 5.3 Selecting a wavelength

To select a wavelength proceed as follows:



- Procedure**
1. Use the arrow keys to navigate the cursor in one of the two fields for the wavelength.
  2. Enter the desired value using the numeric pad after activation via confirmation button  or use the vertical arrow keys  .
  3. If only one wavelength is to be used, then a zero must be entered in the unused field. This deactivates the corresponding detector channel.
  4. Confirm entry by using the horizontal arrow keys  .



**Note:** Two spectral edge filters to suppress the second diffraction order are automatically activated, if the shortest wavelength in all active channels exceeds an internal default value. The activated filter is indicated by the raised + in front of the specification of the wavelength.

#### 5.3.1 Options for signal output

You can configure the output of a measurement as follows:

- Procedure**
1. Position the cursor in one of the two fields for the signal output.
  2. Use the vertical arrow keys   to select one of the following options:

Options	Explanation
„-“	The absorbtion value is inverted.
„1/2“	The absorbtion of channel 1 is divided by the absorbtion of channel 2.
„2/1“	The absorbtion of channel 2 is divided by the absorbtion of channel 1.

The absorption ratio of the measurement can thus be generated to check the chromatographic separation quality at two wavelengths. The ratio values are displayed by the symbols 1/2 or 2/1 at the decimal point of the absorption value.







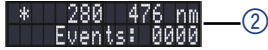



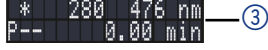

Fig. 14 Signal output option „1/2“





## 5.4 Menu structure

### 5.4.1 Main menu

The main menu contains the current parameters of the detector.

Process	Figure
1. To navigate between the different main menus, use the horizontal arrow keys   .	
2. In the three main screens the selected wavelength, absorbance values  , and events  can be adjusted, and programs can be started  .	
3. To access the submenus <i>DEVICE SETTINGS</i> , <i>DEVICE GLP</i> , <i>LAMPS GLP</i> , <i>DEVICE PROGRAMS</i> and <i>DEVICE LINKS</i> use the menu button  and the horizontal arrow keys   .	

#### Navigate through main menu

- Procedure**
1. Press  to access the menu.
  2. Navigate between menu points by using horizontal arrow keys  .
  3. Enter submenus using .



**Note:** With the vertical keys, you can increase and decrease the displayed values or activate an option, after moving the blinking cursor via the horizontal arrow keys to the value of interest. If you want to use the numeric pad, simply press the confirmation button to activate numeric pad. A decimal point is available via the standby key in case the numeric pad is activated.

### 5.4.2 Menu structure: overview









Fig. 15: Menu structure: overview

### 5.4.3 Device setting parameters

The device settings can be displayed and changed via this menu. All parameters are explained in the following table.

#### Navigate through the device settings menu

1. Select the Device Settings menu.
2. Use the horizontal keys   to navigate through the submenu.
3. The detector will jump back to the main menu after a short time if you do not press any keys.
4. See section 5.4.1 for an explanation how to change editable values.

Menu	Explanation	Figure
<b>Control Setup</b>	<p>Setting for external communication connection of the detector. The connections are on the rear of the device.</p> <ul style="list-style-type: none"> <li>Serial interface: RS232-115200, RS232-38400, RS232-19200, RS232-9600</li> <li>LAN-DHCP: Automatic network configuration</li> <li>LAN manual: Manual network-configuration (Port, IP address, IP mask, Gateway)</li> <li>Analog: Manual control of the detector (also see menu item "Analog input setup")</li> </ul>	
<b>D2 Lamp/ Halogen Lamp</b>	<p>Switch lamps off and on.</p> <p><b>Note:</b> A restart of the D2 lamp will start a recalibration.</p>	
<b>Calibration restart</b>	<p>Initiate a recalibration of the detector.</p>	
<b>Time constant</b>	<p>Here a time constant can be selected from prescribed values (0.1 s; 0.2 s; 0.5 s; 1 s; 2 s; 5 s; 10 s) to smooth the analog output signal. The larger the value of the selected time constant, the stronger the applied signal smoothing.</p>	
<b>Date/Time</b>	<p>Change real time clock date and time of the detector.</p>	

### Intensity monitor

Press the confirmation key  to enter the submenu:

```
INTENSITY
MONITOR >
```

- Via *Monitor source* the type of signal can be selected (absorption, signal channel intensity, reference channel intensity).
- *I (sig/ref)* provides the actual light intensities measured for signal- and reference channel.
- *P @max (sig/ref)* provides the absolute light intensity of signal- and reference channel at the UV-maximum, measured after a calibration. The values are independent from the integration time default setting and can be used as a spectral sources' quality gauge. Further, the intensity of the signal channel allows you to draw conclusions about the measurement situation of the optical flow cell path. (installed flow cell type, solvent usage, bubble free, etc.).
- As part of the calibration procedure, the integration time parameter is automatically adjusted in order to optimize the dynamic range of the light intensity measurement.

### Scan settings

- Via *Integrator ch.* the output channel for the scan can be selected.
- The parameter *Speed* defines the rate (wavelength/time) at which the spectral data are send as an analog signal to the integrator port.

```
Integrator ch.:1
Speed: 4 nm/s
```

### Fraction collection

A fraction collector can be controlled through the pin header/remote connector on the back of the detector. Press the confirmation key  to enter the submenu:

- The *Fraction level* is used to specify the signal height that needs to be exceeded to switch on the fraction collection.
- With the *Fraction delay* the propagation delay due to the dead volume of the capillaries between detector and fraction collector is considered.
- When the set threshold in the *Fraction level* is exceeded, the event output selected in the *Fraction port* line is switched on and remains active until the signal drops below the threshold value. The threshold always relates to the signal on the measurement channel. The following event outputs can be selected via the *Fraction port parameter* (please also see pin header connectors section for details on TTL-level and permissible loads, etc.):
  - Event 1 (relay contact via pin header „EV1“)
  - Event 2 (TTL output via pin header „EV2“)
  - Event 3 (TTL output via pin header „EV3“)
  - 24V (+24V via pin header „24V valve“)



### Analog output setup

Here the *offset* (constant baseline shift) and the *scale* (in au/V) of the integrator outputs can be set. For the recording of possible negative absorption values, an according offset has to be predefined, since the integrator is providing positive voltage levels only. Otherwise all absorption values/voltage levels below zero will be clipped.













<b>Analog input setup</b>	<p>The external <math>\lambda</math> input pin header connector on the back of the device enables external control of the wavelength active for channel 1 of the detector, through a positive analog voltage that is applied against the pin header connector AGND.</p> <ul style="list-style-type: none"> <li>■ By activating <i>Set zero</i> (by using the vertical arrow keys) a voltage can be defined as the spectral zero point for the wavelength 000 nm. Typically, a voltage of 0 is used in this case.</li> <li>■ If a different positive control voltage is applied, the current "<math>\lambda</math>" field displays a resulting wavelength with a scaling factor of 100 nm/V.</li> <li>■ This wavelength (WL) can then be adjusted. Thus, a second calibration point is generated, which modifies the scaling factor.</li> </ul> <p><b>Note:</b> Before operating this configuration, change the communication setup of the detector to <i>Analog</i> (see also <i>Control Setup</i> option above).</p>	
<b>Event check</b>	<p>Check the functionality of the terminal strip/pin header connectors.</p> <ul style="list-style-type: none"> <li>■ <b>Inputs:</b> Menu shows the status of "Start IN", "Error IN" and "Autozero" (0 - inactive, 1 - active).</li> <li>■ <b>Activate only:</b> Activate events 1 - 3, named "EV1", "EV2" and "EV3" and +24V voltage output.</li> </ul> <p><b>Note:</b> Please also see „4.7.2 Connecting the pin header“ on p. 28 for details on permissible signal voltages, loads, etc.</p>	
<b>Display setup</b>	<p>Adapt <i>Brightness</i> and <i>Contrast</i> of the display, as well as the brightness of the status LED via <i>LED power</i>.</p>	







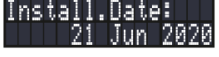

## 5.5 GLP menu

The *GLP* (Good Laboratory Practice) menu is for information purposes only. The submenus provide information about the device history, deliver an overview of the device configuration, and inform about the condition of detector and lamps.

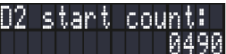
### Navigate through GLP menu

- Procedure**
1. Select the device and lamps GLP menus.
  2. Use the horizontal keys   to navigate through the submenu.
  3. If no buttons are pressed, the display returns to the main menu after a short time.
  4. The menu contains no editable parameters.

Menu	Explanation	Figure
<b>DEVICE GLP</b>		
<b>Serial number</b>	Detector serial number	
<b>Operating time</b>	Detector operating time	
<b>Motor Working</b>	Grating motor operating (movement) time	
<b>CALIBRATION INFO</b>	Menu shows the line density of the optical grating as well as the fine deviation of the zeroth spectral order. Both values are used for exact wavelength calibration of the optical grating of the detector.	
<b>VALIDATION INFO</b>	Menu shows the results of the self-test for optical bandwidth and stray light rejection level (maximum order filter absorbance) as well as the validation of spectral positions of optical absorption peaks of Holmium oxide and optical intensity peaks (H-beta spectral line).	
<b>Firmware Version/Display firmware</b>	Currently installed Firmware Versions for detector and detector display.	
<b>Install. Date Service Date</b>	Display of the initial installation and last service.	















<b>LAMPS GLP</b>		
<b>D2 serial nr.</b>	D2 lamp serial number	
<b>D2 start count</b>	Number of overall D2 lamp ignitions	
<b>D2 operating</b>	D2 lamp operating time	
<b>HAL serial nr.</b>	Halogen lamp serial number	
<b>HAL operating</b>	Halogen lamp operating time	
<b>Power supply SN</b>	Lamp power supply serial number	
<b>PS operating</b>	Lamp power supply operating time	
<b>Power supply FW</b>	Lamp power supply currently installed firmware version	

## 5.6 Program menu

The menu Program is used to list and create programs. The detector can save up to 19 programs and up to 100 program lines with the following functions:

- Start time
- Wavelength
- Events

### Navigate through Program menu









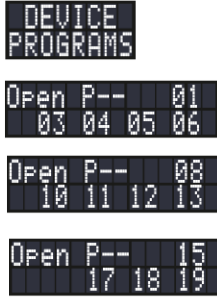

- Procedure**
1. Select the Device Programs menu.
  2. Use the horizontal arrow keys   to scroll through the list of stored programs. Select a program number of your choosing (from the currently displayed screen) by using the vertical arrow keys   or the confirmation key combined with the numeric keypad. Finally, confirm the selected program by using the confirmation key .
  3. Use the horizontal arrow keys   to navigate through the display and to switch between wavelength and event selection screens.
  4. Change a value, using the vertical arrow   keys or the confirmation key  combined with the numeric keypad. Use the confirmation button  to save the settings.
  5. Move the cursor to the double arrow on the lower left line to navigate to the next line of the program or to create a new line.
  6. To create a new line, set the start time for the new program step using the vertical arrow keys   or the confirmation key  combined

with the numeric keypad. Use the confirmation key  to continue with the setting of wavelength and events of this program line (use horizontal keys to switch between parameters as well as between wavelength and events screen).



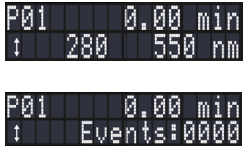



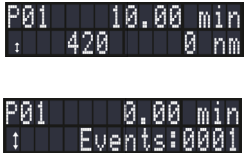









### 5.6.1 Creating a program

The use of the display is demonstrated using this exemplary program:

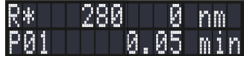
Program 01 is used to monitor absorbance at 280 nm and 550 nm for the first 10-minute step and at 420 nm during the next step, which has no time limit, since it is the final step in this example. Additionally, event 1 is enabled during the second step.

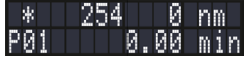
Process	Figure
<ol style="list-style-type: none"> <li>1. Select the device programs menu.</li> <li>2. Select a program number (from the currently displayed screen).</li> </ol>	
<ol style="list-style-type: none"> <li>3. Adapt time-, wavelength- and event-parameters by navigating via horizontal keys   and editing via vertical keys   or via usage of confirmation key  and numerical keypad.</li> </ol>	
<ol style="list-style-type: none"> <li>4. Navigate to the double arrow on the lower left side of the display and press the downward key  to create a new line.</li> <li>5. Edit the time value of the new line and confirm via the confirmation key .</li> </ol>	
<ol style="list-style-type: none"> <li>6. Edit wavelength and events as done before (see also step 3).</li> <li>7. Press the menu key  for 2 seconds to exit the submenu. The program is automatically saved.</li> </ol>	

## 5.6.2 Running a program

Process	Figure
<ol style="list-style-type: none"> <li>Navigate through the main screen using the horizontal arrow keys   to get to the program/link screen.</li> <li>Move the cursor to the area behind the P, press  and type in the program number via the numeric pad or use the vertical arrow keys  .</li> <li>Upon entering the program number, the detector will load the program and program status will be shown in the first line (left) as „H“ („H Hold“).</li> </ol>	  
<ol style="list-style-type: none"> <li>Navigate the cursor with the horizontal keys   to the status symbol "H" and press the upward key  to change the status from Hold "H" to Run "R" (program starts running).</li> </ol>	
<ol style="list-style-type: none"> <li>You can again go back from Run "R" to hold "H" by pressing the downward key  with the cursor at the status symbol position at any time.</li> <li>You can unload the program by pressing the downward key  another time ("H" will disappear) and the detector settings before the start of the program will be restored.</li> </ol>	
<ol style="list-style-type: none"> <li>After the program has been completed, the display switches into the status "E" (End). The detector will preserve the settings of the last program line until you clear the program status.</li> <li>To do so, navigate the cursor to the program status symbol and use the downward key  to clear the status. Also, you might press the upward key  to return to hold and run mode.</li> </ol>	

### 5.6.3 Changing a program

When new values for the different program lines are entered, the old values are overwritten.



**Note:** If a program/link is selected in the program/link screen (see above), a program that is part of that program/link cannot be edited. Select program/link "P00"/"L00" in the main screen to unload the program/link, first.

- Procedure**
1. Select the device programs menu.
  2. Select the program number you wish to change.
  3. Navigate to the line and value you wish to change.
  4. Activate the numeric pad by pressing the confirmation key and enter a new value or use the vertical arrow keys.

### 5.6.4 Deleting a program line





Process	Figure
<ol style="list-style-type: none"> <li>1. Select the device programs menu.</li> <li>2. Select the program number you wish to change.</li> <li>3. Navigate to the to be deleted program line.</li> <li>4. Change the time value of this line to 0.0.</li> <li>5. You will be asked whether you want to delete the program line. Confirm with the confirmation key  or deny with the menu key .</li> </ol>	

### 5.6.5 Deleting a program

Process	Figure
<ol style="list-style-type: none"> <li>1. Select the Device Programs menu.</li> <li>2. Select the program 00.</li> <li>3. You will be asked which program you want to delete. Activate the numeric pad by pressing the confirmation key  and enter the program number you wish to delete (e.g., P01).</li> <li>4. You will be asked whether you really want to delete the program. Confirm with the confirmation key  or deny with the menu key .</li> </ol>	





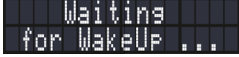









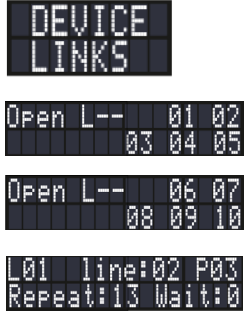

### 5.6.6 Creating and running a program with preselectable start time (Wake-Up Program)

The detector can start a program at a preset time (wake-up program). This program is preset at number 20. The detector starts the selected program at the specified time and date. The display switches from standby ("Waiting for WakeUp") to "R" (Run) mode.

Process	Figure
<ol style="list-style-type: none"> <li>1. Select the Device Programs menu.</li> <li>2. Enter program number 20.</li> <li>3. Enter wake-up time, -date and the program number you wish to start by navigating via the horizontal arrow keys   and editing via the numeric keypad after pressing the confirmation key  or using the vertical arrow key.</li> <li>4. To run the wake-up program, follow the procedure as if running any other program and confirm the start of the wake-up program 20.</li> </ol>	 
<ol style="list-style-type: none"> <li>5. Upon choosing program number 20 the detector will go into standby mode (status LED switches to blue) until the set wake-up time and date.</li> <li>6. Before running the program, the detector will perform a self-calibration.</li> <li>7. By pressing the standby button for 2 seconds the device will immediately start to recalibrate, interrupting the standby and deactivating the wake-up program.</li> </ol>	

## 5.7 Device Links

The Link menu displays the status of active links. Max. 10 program links between defined programs can be created and saved.

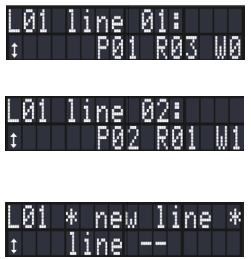
Process	Figure
<ol style="list-style-type: none"> <li>1. Select the Device Links menu.</li> <li>2. Use the horizontal arrow keys   to scroll through the list of stored links. Select a link number of your choosing (from the currently displayed screen) by using the vertical arrow keys   or the confirmation key  combined with the numeric pad.</li> <li>3. Finally, confirm the selected link by using the confirmation key .</li> </ol>	 <pre> DEVICE LINKS Open L-- 01 02           03 04 05 Open L-- 06 07           08 09 10 L01 line:02 P03 Repeat:13 Wait:0 </pre>
<ol style="list-style-type: none"> <li>4. After selecting a link, use the horizontal arrow keys   to navigate through the two lines of the display and to switch between lines, program, repetitions and wait status.</li> <li>5. To change a value, use the vertical arrow keys   or press the confirmation button  and change the value by the numeric keypad, after moving the cursor to the position of interest.</li> <li>6. Move the cursor via the horizontal arrow keys   to the double arrow on the lower left corner.</li> <li>7. Use the vertical arrow keys   to navigate to the next line or create a new line.</li> </ol>	 <pre> L01 line 01: ↑ P01 R03 W0  L01 line 02: ↑ P02 R01 W1  L01 * new line * ↑ line -- </pre>















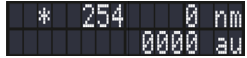
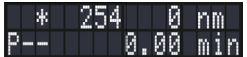

## 5.7.1 Creating a Link

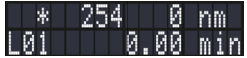

**Note:** If W1 (W = Wait) is used, the detector waits in Hold mode (“H”) for an external start signal or for the user to press the upward key to set the status to Run (“R”) before executing this line. If the W0 setting is used, the link sequence is run without interruption.

Process	Figure
1. Select the Device Links menu.	
2. Enter the link number (from the currently displayed list).	
3. Press the confirmation button  to enter the editing mode of the link.	
4. Move the cursor to position P (P = Program) in the display and enter the program number you wish to run.	
5. Move the cursor to position R (R = Repeat) and edit the value (number of repetitions for the specified program).	
6. Move the cursor to position W (W=Wait) in the display and select 0 (do not wait) or 1 (wait).	
7. Create a new line by moving the cursor to the lower left corner and navigate through individual link lines via the horizontal arrow keys   until you reach the “new line” screen.	
8. Navigate the cursor to the line number and enter the number of the new line via vertical arrow keys   or confirmation key  and numerical keypad.	
9. Confirm the new line number via the confirmation key . Now, you can edit the values of the new line, as done before.	

## 5.7.2 Running a Link

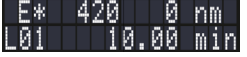
Process	Figure
<ol style="list-style-type: none"> <li>1. Select the Device Links menu.</li> <li>2. Navigate through the main screen using the horizontal arrow keys   to get to the program/link screen.</li> <li>3. Move the cursor to the area to the "P" and press the vertical arrow key to switch to "L" (Link) mode.</li> </ol>	 
<ol style="list-style-type: none"> <li>4. Move the cursor to the position right next to the "L" and select the desired link number via confirmation key  and numeric keypad or via vertical arrow keys  .</li> <li>5. After confirming the selected link number via the confirmation key , the detector status will switch to hold ("H").</li> </ol>	  
<ol style="list-style-type: none"> <li>6. Navigate the cursor to the "H" (hold) position and start running the link via the upward arrow key . The detector status will switch to "R" (run) mode.</li> <li>7. The link will start running the programs line by line.</li> <li>8. Use the downward arrow key  with the cursor on the detector status to pause the execution of the link. Status switches to "H" (Hold). If the detector is waiting for an event (W1 option selected in the respective link line) it will also enter the hold state.</li> <li>9. To resume the run, press the upward arrow key . Status will switch to "R" (Run).</li> <li>10. After the link has been completed, the status will switch to "E" (End). Navigate the cursor to the link status and press the upward key  to return to hold and run mode.</li> <li>11. Use the downward key  to clear the status.</li> </ol>	

### 5.7.3 Changing a Link

If new values for the different line parameters are entered, the old values are overwritten.



**Note:** If a program/link is selected in the program/link screen (see above), a program that is part of that program/link cannot be edited. Select program/link "P00"/"L00" in the main screen first to unload the program/link, first.

**Procedure**

1. Select the device links menu.
2. Select the link number you wish to change.
3. Navigate to the line and value you wish to change.
4. Navigate to the parameter you would like to change and edit its values via confirmation key and numeric keypad or via vertical arrow keys .

### 5.7.4 Deleting link lines

Process	Figure
<ol style="list-style-type: none"> <li>1. Select the Device Links menu.</li> <li>2. Select the link number you wish to change.</li> <li>3. Navigate to the to be deleted link line (e.g. line 02).</li> <li>4. Change the line number to "00".</li> <li>5. You will be asked whether you want to delete the link line which was active before entering 00.</li> <li>6. Confirm via the confirmation key  or deny via the menu key .</li> </ol>	  

### 5.7.5 Deleting a Link

Process	Figure
<ol style="list-style-type: none"> <li>1. Select the Device Links menu and select the link 00.</li> <li>2. You will be asked which link you want to delete. Use either the confirmation key  and numeric keypad or the vertical arrow keys   to select the link number you wish to delete.</li> <li>3. After pressing the confirmation key , you will be asked whether you really want to delete the selected link.</li> <li>4. Confirm once more with the confirmation key  or deny with the menu key .</li> </ol>	 

## 5.8 Scan menu



To open the scan menu, press the scan menu button  on the keypad. The menu enables the selection of the wavelength range for the scan and the autozero scan as well as the output of the saved scan data.

### 5.8.1 Autozero scan

Before recording spectra, the detector must perform the so-called autozero scan. During this procedure, the solvent spectrum is measured and the measurements along the entire set wavelength range are set to zero.











**Note:** For each change of solvent, the autozero scan should be performed again

- Procedure**
1. Press the scan menu button  on the keypad.
  2. Set the wavelength range for the autozero scan.
  3. Press the autozero button  on the keypad.

### 5.8.2 Wavelength scan

For a wavelength scan, the UV spectrum of a sample is recorded. The wavelength of light at the output gap is changed by turning the optical grating continuously. During the procedure, the light absorption is measured constantly.

Process	Figure
<ol style="list-style-type: none"> <li>1. Press the scan menu button  on the keypad.</li> <li>2. Choose the signal source (absorption; int-sig; int-ref) and the wavelength range of interest by navigating through the display via arrow keys and numeric pad.</li> <li>3. To start the scan, press again the scan menu button . The scan is executed immediately and saved. Afterwards the display returns to the main menu.</li> </ol>	
<p>To subsequently output the saved scan over Integrator 1 (analog), proceed as follows:</p> <ol style="list-style-type: none"> <li>1. Press the scan menu key  to enter the menu.</li> <li>2. Using the arrow keys  , position the cursor in the lower right corner of the display and press the confirmation key  to activate the scan output.</li> <li>3. The progress of the output will be indicated by the continuing rise in the wavelength.</li> </ol>	

## 6. Functionality tests



**Note:** Standard processes regarding IQ and OQ in single devices may be handled differently in individual cases.

### 6.1 Installation Qualification (IQ)

The customer may request the Installation Qualification, which is free of charge. In case of a request, the technical support of KNAUER or a provider authorized by KNAUER performs this functionality test during the installation.

The Installation Qualification is a standardized document that includes the following:

- confirmation of flawless condition at delivery
- check if the delivery is complete
- certification on the functionality of the device

You can either use the IQ document attached to this instruction manual or download a digital version from our website:



### 6.2 Operation Qualification (OQ)

The Operation Qualification includes an extensive functionality test according to KNAUER standard OQ documents. The Operation Qualification is a standardized document and free of charge. It is not part of the delivery. Please contact the technical support in case of a request.

The Operation Qualification includes the following:

- definition of customer requirements and acceptance terms
- documentation on device specifications
- device functionality check at installation site

**Test intervals** To make sure that the device operates within the specified range, you should test the device regularly. The test intervals depend on the usage of the device.

**Execution** The test can be carried out either by the technical support of KNAUER or by a provider authorized by KNAUER (for a fee). For further information visit our website:



## 7. Troubleshooting

First measures:

- Check all cables and fittings.
- Check if air has gotten into the supply lines.
- Check the device for leakages.

Further measures:

- Compare occurring errors with the list of possible errors (see below).
- Install maintenance software (service tool).
- Save device information and send to manufacturer.
- Contact the Customer Support.

### 7.1 LAN

Go through the following steps, in case no connection between the computer and the devices can be established. Check after each step if the problem is solved. If the problem cannot be located, call the technical support.

1. Check the status of the LAN connection in the Windows task bar:



If no connection was established, test the following:

- Is the router switched on?
  - Is the patch cable connected correctly to the router and the computer?
2. Check the router settings:
    - Is the router set to DCHP server?
    - Is the IP address range sufficient for all the connected devices?
  3. Check all connections:
    - Are the patch cable connected to the LAN ports and not the WAN port?
    - Are all cable connections between devices and router correct?
    - Are the cables plugged in tightly?
  4. If the router is integrated into a company network, pull out the patch cable from the WAN port.
    - Can the devices communicate with the computer, even though the router is disconnected from the company network?
  5. Turn off all devices, router, and computer. First switch on the router and wait until it has successfully completed its self-test. Firstly, turn on the router and secondly turn on the devices and the computer.
    - Has this been successful?
  6. Replace the patch cable to the device with that no connection could be established.
    - Has this been successful?
  7. Make sure that the IP port of the device matches the port in the chromatography software.

## 7.2 Possible problems and solutions

Issue	Solution
Baseline drift	Maintain constant temperature conditions during the measurement.
Device will not turn on	Inspect the power cable to be sure it is plugged into the power supply.
Device cannot be calibrated	<ul style="list-style-type: none"> <li>■ Fasten the knurled-head screws on the flow cell to prevent incursion from interfering light or an electronics error.</li> <li>■ Insert the test cell.</li> <li>■ Inspect the calibration with a weak absorbing eluent.</li> </ul>
Baseline noise	<ul style="list-style-type: none"> <li>■ Inspect the flow cell assembly.</li> <li>■ Fasten the knurled-head screws on the flow cell to prevent incursion from interfering light or an electronics error.</li> <li>■ Replace the defective flow cell.</li> <li>■ Inspect the operating time of the Deuterium- and Halogen lamp via the lamps GLP menu.</li> <li>■ Reduce the air in the flow cell by using a degasser.</li> </ul>
The relationship of the signal to the light path reference is very low	<ul style="list-style-type: none"> <li>■ Rinsing the flow cell.</li> <li>■ Clean the flow cell window.</li> <li>■ Exchange lamp (spectrum source).</li> </ul>

## 7.3 System messages

If other system messages are displayed besides those listed below, please turn the device off and then on. Inform the technical support in case the system message repeats.

The system messages are in alphabetical order:

System message		
<b>A</b>	"At least one wavelength must be valid"	Check whether a channel is on. Check whether the wavelengths are within permissible range (190 to 750 nm).
<b>C</b>	"Calibration failed"	Switch the modules off and turn them back on. Check whether lamps, motor and filter are functioning correctly. If the system message appears again, notify Technical Support. Restart calibration at the module or in the chromatography software.
	"Cannot delete active program/link"	First pause link, then delete program.
	"Cannot edit program from the running link"	First pause link, then edit data using chromatography software.
	"Cannot initialize LAN"	Check cables and connections in local area network.
	"Cannot operate an uncalibrated instrument"	Switch the device off and on. Wait until calibration is completed.
	"Cannot operate with an empty link"	Create a link.
<b>D</b>	"D2-Lamp does not start!"	Switch off lamp on touchscreen and turn it on again. If the system message appears again, notify Technical Support. The lamp unit has to be replaced.
	"Data acquisition active"	No entries are possible. First stop acquiring measurement data, afterwards you can make a new entry.
<b>F</b>	"Filter move error"	Switch the device off and on. If the system message appears again, notify Technical Support.
<b>I</b>	"Instrument remote controlled"	This entry is not executable. Quit software.
	"Invalid command"	Check the cable connections. Change the entry.



System message		
	"Invalid parameter(s)"	Check the validity of the parameters.
	"Invalid time in time table"	Correct the time entry.
	"Invalid time table index"	Change the entry in the program line.
<b>L</b>	"Link is loaded"	First unload the link then change the link or delete it.
	"Link is running"	Wait until the link has been completed, then change the link or delete it.
<b>N</b>	"No link available"	Create a link and edit it.
	"No link available, pls edit link first"	Create a link and edit it.
	"No time table to start"	Edit or enter a time table.
	"Not enough space to store link"	Check the detector. Check the number of program lines. A maximum of 50 program lines are possible.
	"Not enough space to store program"	Check the detector. Check the number of program lines. A maximum of 50 program lines are possible.
<b>P</b>	"Program does not exist"	Create a program.
	"Program is running"	Quit program or wait until program has been completed.
<b>S</b>	"Scan is already active"	Cancel scan procedure or wait until scan procedure has been completed.
<b>T</b>	"This link is used in Wake up"	First quit or delete wakeup program (wu = Wake Up), then edit or delete link.
	"This program is used in a link"	First pause or delete link, then edit or delete program.
	"This program is used in Wake up"	First quit or delete wakeup program (wu = Wake Up), then edit or delete program.
	"Time already exists"	Correct the time entry.
	"Time table is not active"	The device is in <i>Standalone</i> mode, no program is running. If you try to quit a non-existent program sequence, this message appears.

<b>System message</b>	
"Time table is not loaded"	First load the program, then start the program.
"Time table line is empty"	Edit the program line.
"Too many lines in program"	Check the number of program lines. A maximum of 100 program lines are possible.
<b>W</b> "Wrong Line number"	Change the entry in the program line.

## 8. Maintenance and care

Maintenance of a HPLC instrument is critical to the success of analyses and the reproducibility of results. If you require a maintenance task which is not described here, contact your dealer or the Customer Support.

### DANGER

#### Electric shock

High voltages inside the detector pose a life threatening risk.

- Call an authorized service technician to open the housing and replace the lamp.

### WARNING

#### Eye injury

Irritation of retina through UV light. High-energy UV light can leak out from the flow cell or the fiber optic connectors.

- Switch off the detector or the lamps.

### 8.1 Maintenance contract

The following maintenance work on the device may only be performed by KNAUER or a company authorized by KNAUER and is covered by a separate maintenance contract:

- Opening the device or removing housing parts.

### NOTICE

#### Electronic defect

Performing maintenance tasks on a switched on device can cause damage to the device.

- Switch off the device.
- Pull the power plug.

Users may perform the following maintenance tasks themselves:

- Regularly check the light intensity of the D<sub>2</sub> lamp (at least before 2000 operating hours).
- Inspect the flow cell assembly.
- Clean the flow cell.
- Replace the flow cell.

## 8.2 Cleaning and caring for the device

All smooth surfaces of the device can be cleaned with a mild, commercially available cleaning solution, or with isopropanol.

**Display** Displays can be cleaned with isopropanol and wiped dry with a soft, lint-free cloth.

### NOTICE

#### Device defect

Intruding liquids can cause damage to the device.

- Place solvent bottles next to the device or in a solvent tray.
- Moisten the cleaning cloth only slightly.

## 8.3 Cleaning the flow cell

Increased baseline noise and reduced sensitivity can be a result of a dirty flow cell. Often it is sufficient to rinse the flow cell to restore optimal sensitivity.



**Note:** Dirty lenses or fiber optic connectors could falsify the measurement. Do not touch the lens or the fiber optic connector lenses with bare hands. Wear gloves.

### 8.3.1 Rinsing the flow cell

#### NOTICE

#### Performance decrease

For the drying step, oil drops from compressed air can contaminate the flow cell which may result in performance decrease.

- Do not use compressed air for drying.

**Prerequisite**

- Flow cell is removed from the detector.
- Waste tube is connected to the flow cell.

**Solvents** The following solvents are recommended for rinsing:

- Diluted HCl (1 mol/L)
- 1 ml/L NaOH aq.
- Ethanol
- Acetone

**Tools** Syringe

#### Process

1. Fill the syringe with eluent.
2. Inject it into the inlet of the flow cell and allow it to act for 5 minutes.
3. Fill the syringe with water and rinse the inlet.
4. Use a nitrogen stream to dry the flow cell.

**Result** The flow cell is rinsed.

- Next steps**
- Check if the baseline noise has decreased.
  - If the rinsing does not have the desired effect, disassemble the flow cell to clean the lens.

### 8.3.2 Cleaning the lens of an analytical flow cell

- Prerequisite**
- Device has been switched off.
  - Power plug has been pulled.
  - Flow cell has been removed.

- Tools**
- Tweezers
  - Allen screwdriver, size 3

- ① Threaded ring
- ② Compression part
- ③ Lens
- ④ Seal ring

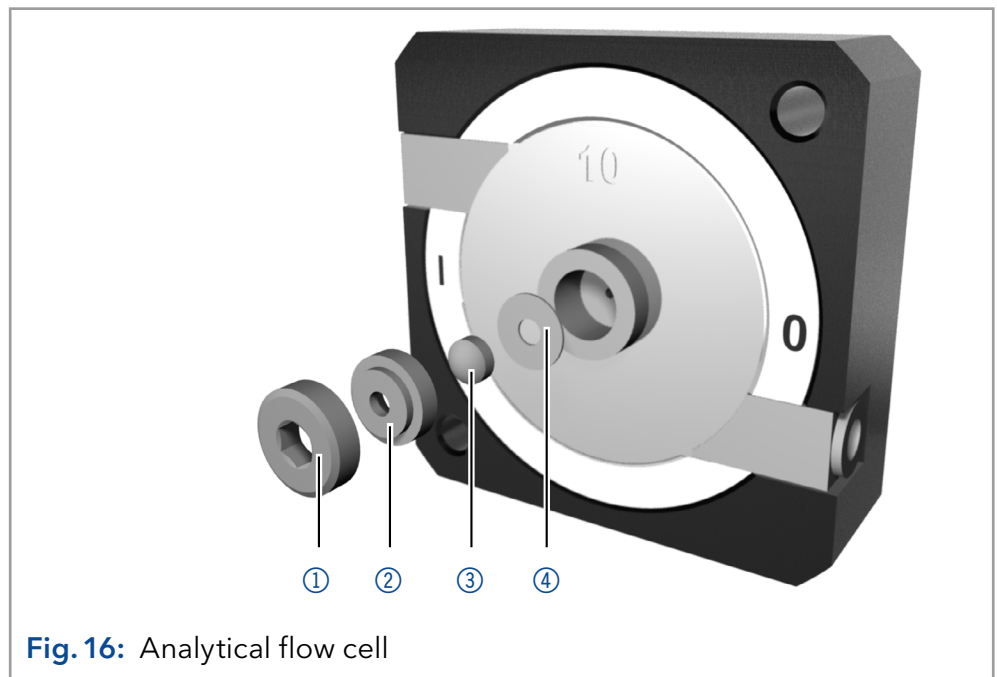

**Fig. 16:** Analytical flow cell

#### Process

1. Using the allen screwdriver, loosen the threaded ring ①.
2. Using tweezers or by gently tapping on a clean surface, remove the compression part ②.
3. The lens ③ is protected by a seal ring ④. This must be renewed every time the lens is disassembled.
4. Remove the lens and clean with a clean, soft cloth or with water in an ultrasonic bath.
5. Assemble the flow cell. Make sure that the new seal ring does not interrupt the light path.
6. Using the allen screwdriver, tighten the threaded ring ① with a torque of 1 Nm.

**Result** The lens of the flow cell has been cleaned.



**Note:** If the cleaning of the lens does not have the desired effect, the lens has to be replaced.

**Next steps** Mount the flow cell onto the detector.

### 8.3.3 Cleaning the light guide of a preparative flow cell

The preparative flow cells have a rod shaped light guide instead of the concave lens of the analytical cells.

**Prerequisite**

- Device has been switched off.
- Power plug has been pulled.
- Flow cell has been removed.

**Tools**

- Tweezers
- Allen screwdriver, size 3

- ① Threaded ring
- ② Cover
- ③ Spacer
- ④ Pressure bushing
- ⑤ Light guide with seal ring

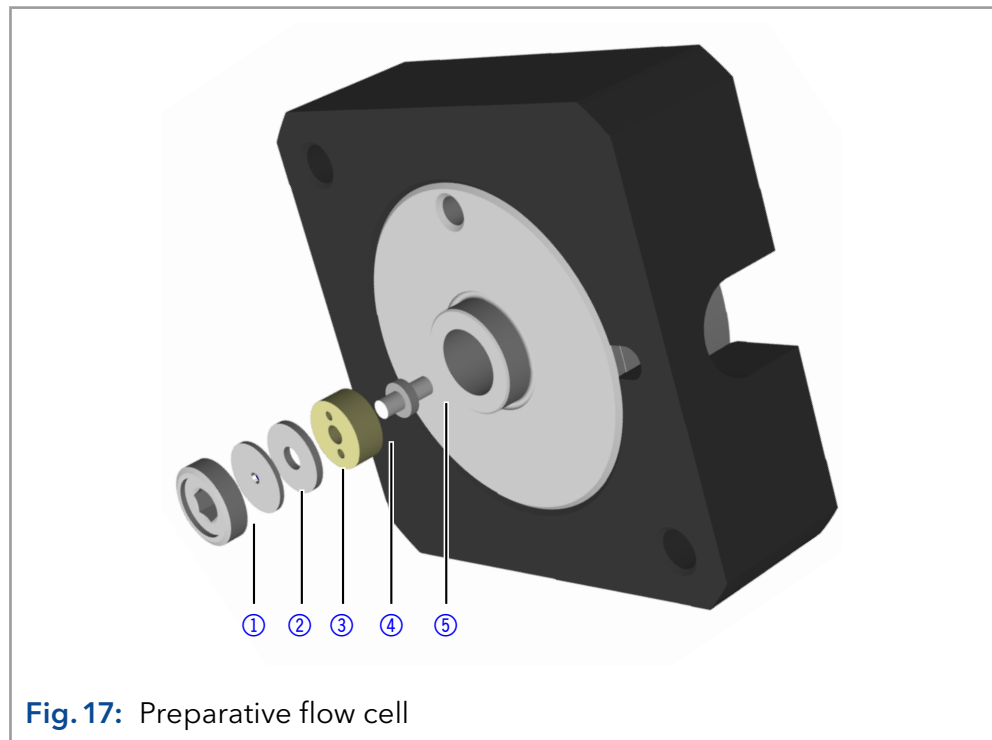

### Process

1. Using the allen screwdriver, loosen the threaded ring ① .
  2. Remove the cover ② and the spacer ③ (not part of all flow cells).
  3. Using tweezers, pull out the pressure bushing ④ and the light-guide ⑤ .
  4. Carefully push the light guide out of the holder and strip off the seal. The seal ring needs to be renewed during every cleaning of the fiber optics.
  5. Clean the light guide with a clean, soft cloth or with an appropriate solvent in an ultrasonic bath. Make sure that the clean light guide is not touched by fingers.
  6. Assemble the flow cell.
  7. Using the allen screwdriver, tighten the threaded ring ① .
- 

**Result** The the light path of the flow cell has been cleaned.



**Note:** If the cleaning of the light guide does not have the desired effect, the light guide has to be replaced.

**Next steps** Mount the flow cell onto the detector.

## 8.4 Replacing the flow cell

UV light will cause the flow cells to become blind with time (solarization), making them no longer suitable for use.

- Prerequisite**
- The device has been switched off.
  - The power plug has been pulled.
  - The capillaries have been removed.

### Process

1. Remove capillaries at the inlet ① and outlet ② of the flow cell.
2. Unscrew the knurled-head screws ③ of the cover plate ④. Hold the flow cell securely with your hand during this procedure.
3. Pull out the slide with the flow cell ⑤ towards the front.
4. Remove the flow cell upward.
5. Insert new flow cell from above into the flow cell holder. Keep holding the flow cell.
6. Push the flow cell holder against the detector again.
7. Screw the knurled-head screws back into the cover plate ④ and tighten.

### Figure

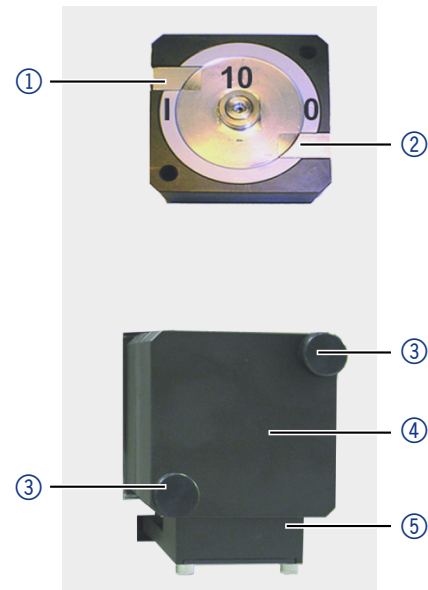

**Fig. 18:** Replacing the flow cell

**Result** The flow cell has been assembled.

**Next step** Connect the capillaries.



## 9. Transport and storage

Regarding the following information, carefully prepare the device for transport or storage.

### 9.1 Taking the device out of operation

**Prerequisites** The device is switched off.

#### Process

1. Pull the power plug out of the socket and then out of the device.
2. Pack the power cable together with the device.

**Next steps** Disconnect all electrical connections. Remove the accessories and pack the device for transport or storage.

### 9.2 Packing the device

- Original packaging: Ideally you should use the original transport packaging.
- Lifting: Grab the device around the center of both sides and lift it into the packaging.

### 9.3 Transporting the device

Carefully prepare the device for transport or storage. If you want to return your device to KNAUER for repairs, enclose the [Service Request Form](#) which can be downloaded from our website.

**Device data** For a secure transport, note the weight and dimensions of the device (see „Technical data“ on page 65).

#### ⚠ CAUTION

##### Bruising danger

Damage to the device by carrying or lifting it on protruding housing parts. The device may fall and thus cause injuries.

→ Lift the device only centrally on the side of the housing.

**Lifting** Clasp the device at its side panels and lift it out of the packaging.

### 9.4 Storing the device

Make sure that all tubes and capillaries have been drained or filled with flushing solution (e.g. isopropanol) before storage. To avoid algae formation, do not use pure water. Close all inlets and outlets with blind screwings.

**Storage conditions** The device can be stored under the ambient conditions described in chapter „Technical data“ on page 65.

## 10. Disposal

Hand in old devices or disassembled old components at a certified waste facility, where they will be disposed of properly.

### 10.1 AVV-Marking Germany

According to the German "Abfallverzeichnisverordnung" (AVV) (January, 2001), old devices manufactured by KNAUER are marked as waste electrical and electronic equipment: 160214.

### 10.2 WEEE registration number

KNAUER as a company is registered by the WEEE number DE 34642789 in the German "Elektroaltgeräteregister" (EAR). The number classifies to category 8 and 9, which, among others, comprises laboratory equipment.

All distributors and importers are responsible for the disposal of old devices, as defined by the WEEE directive . End-users can send their old devices manufactured by KNAUER back to the distributor, the importer, or the company free of charge, but would be charged for the disposal.

### 10.3 Eluents and other operating materials

All eluents and other operating materials must be collected separately and disposed of properly.

All wetter components of a device, e. g. flow cells of detectors or pump heads and pressure sensors for pumps, have to be flushed with isopropanol first and water afterwards before being maintained, disassembled or disposed.

# 11. Technical data

## 11.1 Main features

Detector type	Variable multiple wavelength UV/VIS detector
Detection channels	4
Light source	<ul style="list-style-type: none"> <li>■ Deuterium (D<sub>2</sub>) with integrated GLP chip (one lamp version)</li> <li>■ Deuterium (D<sub>2</sub>) and halogen lamps with integrated GLP chip (two lamp version)</li> </ul>
Wavelength range	<ul style="list-style-type: none"> <li>■ 190-750 nm (one lamp version)</li> <li>■ 190-900 nm (two lamp version)</li> </ul>
Optical bandwidth	6 nm at H <sub>α</sub> line (FWHM)
Wavelength accuracy	± 1.5 nm (verification with integrated holmium oxide filter)
Wavelength precision	0.4 nm (ASTM E1657-98)
Noise	± 0.75 × 10 <sup>-5</sup> AU at 254 nm (ASTM E1657-98)
Drift	2.0 × 10 <sup>-4</sup> AU/h at 254 nm (ASTM E1657-98)
Linearity	> 2.8 AU at 274 nm (ASTM E1657-98)
Time constants	0.1/ 0.2/ 0.5/ 1.0/ 2.0/ 5.0/ 10.0 s
Integration time	Automatic

## 11.2 Communication

Maximum data rate	<ul style="list-style-type: none"> <li>■ 50 Hz (LAN) 1 channel</li> <li>■ 20 Hz (Analog) 1 channel</li> <li>■ 10 Hz (RS-232) 1 channel</li> </ul>
Inputs	<ul style="list-style-type: none"> <li>■ Error (IN)</li> <li>■ Start (IN)</li> <li>■ Autozero</li> <li>■ 0-10 V Analog IN</li> </ul>
Outputs	<ul style="list-style-type: none"> <li>■ Events 1-3</li> <li>■ +5 V</li> <li>■ 24 V Valve</li> </ul>
Analog outputs	2 × 0-5 V scalable, 20 bit, offset adjustable

Control	<ul style="list-style-type: none"> <li>■ RS-232</li> <li>■ LAN-DHCP</li> <li>■ Remote connector</li> <li>■ Analog: wavelength control</li> <li>■ Manual: Keypad</li> </ul>
Programming	9 programs, 50 program lines Time-controlled: <ul style="list-style-type: none"> <li>■ Wavelength</li> <li>■ Events</li> <li>■ Fraction valve</li> <li>■ Links</li> <li>■ Wake-up (program, link)</li> </ul>
GLP	Detailed report including lamp recognition, operating hours, lamp(s) operating hours, number of lamp ignitions
Display	Matrix keypad

### 11.3 General

Power supply	<ul style="list-style-type: none"> <li>■ Power input: 100-240 V</li> <li>■ Output: 50-60 Hz</li> <li>■ Maximum power consumption: 75 Watt</li> </ul>
Protection type	IP-20
Dimensions (W × H × D)	242 mm x 169 mm x 399 mm
Weight	<ul style="list-style-type: none"> <li>■ 5.3 kg</li> </ul>
Area of use	For indoor use only
Line voltage fluctuations do not exceed $\pm 10\%$ of normal voltage.	
Oversvoltage category II:	Energy consumers are supplied by a fixed device.
Permitted pollution degree	2
Temperature range	4-40 °C (39.2-104 °F)
Air humidity	below 90 %, non-condensing
Operating height	max. 2000 meters above sea level

## 12. Chemical compatibility of wetted materials



**Note:** The user takes the responsibility for using the fluids and chemicals in an appropriate and safe way. If there is any doubt, contact the Technical Support of the manufacturer.

### 12.1 General

The device is very resistant against a variety of commonly used eluents. However, make sure that no eluents or water come in contact with the device or enter into the device. Some organic solvents (such as chlorinated hydrocarbons, ether) may cause coating damage or loosen glued components by improper handling. Even small quantities of other substances, such as additives, modifiers, or salts can influence the durability of the materials. Exposure time and concentration have a high impact on the resistance.

The following list contains information about the chemical compatibility of all wetted materials which are used in devices made by KNAUER. The data bases on a literature research on the manufacturer specifications of the materials. The wetted materials of this device are listed in the chapter "Technical data".

All resistances mentioned here are for use at temperatures up to 40 °C, unless stated otherwise. Note that higher temperatures can significantly affect the stability of different materials.

### 12.2 Plastics

#### Polyetheretherketone (PEEK)

PEEK is a durable and resistant plastic and, next to stainless steel, the standard material in HPLC. It can be used at temperatures up to 100 °C and is highly chemical resistant against almost all commonly used solvents in a pH range of 1 - 12.5. PEEK is potentially moderate resistant against oxidizing and reducing solvents.

Therefore, following solvents should not be used: Concentrated and oxidizing acids (such as nitric acid solution, sulfuric acid), halogenated acids (such as hydrofluoric acid, hydrobromic acid) and gaseous halogens. Hydrochloric acid is approved for most applications.

In addition, following solvents can have a swelling effect and may have an impact on the functionality of the built-in components: Methylene chloride, THF and DMSO in any concentration such as acetonitrile in higher concentrations.

#### Polyethylene terephthalate (PET, outdated PETP)

PET is a thermoplastic and semi-crystalline material with high wear resistance. It is resistant against diluted acids, aliphatic and aromatic hydrocarbons, oils, fats and alcohols, but not against halogenated hydrocarbons and ketones. Since PET belongs chemically to esters, it is not compatible with inorganic acids, hot water and alkalis. Maximum operating Temperature: up to 120 °C.

**Polyimide (Vespel®)**

This material is wear-resistant and permanent resilient thermally (up to 200 °C) as well as mechanically. It is chemically broadly inert (pH range 1 - 10) and is especially resistant against acidic to neutral and organic solvents, but vulnerable to pH strong chemical or oxidizing environments: It is incompatible with concentrated mineral acids (such as sulfuric acid), glacial acetic acid, DMSO and THF. In addition, it will be disintegrated by nucleophilic substances like ammonia (such as ammonium salts under alkaline conditions) or acetate.

**Ethylene-tetrafluorethylene copolymer (ETFC, Tefzel®)**

This fluorinated polymer is highly resistant against neutral and alkaline solvents. Some chlorinated chemicals in connection with this material should be handled with care. Maximum operating Temperature is 80 °C.

**Perfluorethylenpropylen-Copolymer (FEP), Perfluoralkoxy-Polymer (PFA)**

These fluorinated polymers hold similar features as PTFE, but with a lower operation temperature (up to 205 °C). PFA is suitable for ultrapure applications, FEP can be used universally. They are resistant against almost all organic and inorganic chemicals, except elemental fluorine under pressure or at high temperatures and fluorine-halogen compounds.

**Polyoxymethylene (POM, POM-H-TF)**

POM is a semi-crystalline, high-molecular thermoplastic material which stands out due to its high stiffness, low friction value and thermic stability. It can even substitute metal in many cases. POM-H-TF is a combination of PTFE fibres and acetal resin and is softer and has better slip properties as POM. The material is resistant against diluted acids (pH > 4) as well as diluted lyes, aliphatic, aromatic and halogenated hydrocarbons, oils and alcohols. It is not compatible with concentrated acids, hydrofluoric acid and oxidizing agent. Maximum operating Temperature is 100 °C.

**Polyphenylene sulfide (PPS)**

PPS is a soft polymer which is known for its high break resistance and very high chemical compatibility. It can be used with most organic, pH neutral to pH high, and aqueous solvents at room temperature without concerns. However, it is not recommended for using with chlorinated, oxidizing and reducing solvents, inorganic acids or at higher temperatures. Maximum operating temperature: 50 °C

**Polytetrafluorethylene (PTFE, Teflon®)**

PTFE is very soft and anti-adhesive. This material is resistant against almost all acids, lyes and solvents, except against fluid sodium and fluoride compounds. In addition, it is temperature-resistant from -200 °C to +260 °C.

**Systec AF™**

This amorphous perfluorinated copolymer is inert against all commonly used solvents. However, it is soluble in perfluorinated solvents like Fluorinert® FC-75 and FC-40, and Fomblin perfluor-polyether solvents from Ausimont. In addition, it is affected by Freon® solvents.

**Polychlorotrifluoroethylene (PCTFE, Kel-F®)**

The semi-crystalline thermoplastic material is plasticizer-free and dimensionally stable, even in a wide temperature range (-240 °C to +205 °C). It is moderately resistant against ether, halogenated solvents and toluene. Halogenated solvents over +60 °C and chlorine gas should not be used.

**Fluorinated rubber (FKM)**

The elastomer consisting of fluorinated hydrocarbon stands out due to a high resistance against mineral oils, synthetic hydraulic fluids, fuels, aromatics, and many organic solvents and chemicals. However, it is not compatible with strong alkaline solvents (pH value > 13) like ammonia, and acidic solvents (pH value < 1), pyrrole and THF. Operating temperature: Between -40 °C and +200 °C.

**Perfluorinated rubber (FFKM)**

This perfluoro elastomer has a higher fluorine content as fluorinated rubber and is therefore chemically more resistant. It can be employed at higher temperatures (up to 275 °C). It is not compatible with Pyrrole.

## 12.3 Non-metals

**Diamond-like carbon (DLC)**

This material is characterized by a high hardness, a low coefficient of friction and thus low wear. In addition, it is highly biocompatible. DLC is inert against all acids, alkalis and solvents commonly used in HPLC.

**Ceramic**

Ceramic is resistant against corrosion and wear and is fully biocompatible. An incompatibility against acids, alkalis and solvents commonly used in HPLC is not known.

**Alumina (Al<sub>2</sub>O<sub>3</sub>)**

Due to their high resistance to wear and corrosion, alumina ceramic is used as a coating for mechanically stressed surfaces. It is a biocompatible material with low thermal conductivity and low thermal expansion.

**Zirconium oxide (ZrO<sub>2</sub>)**

Zirconia ceramics are characterized by their high mechanical resistance, which makes them particularly resistant to wear and corrosion. It is also biocompatible, has low thermal conductivity and is resistant to high pressures.

**Sapphire**

Synthetic sapphire is virtually pure monocrystalline alumina. It is biocompatible and very resistant to corrosion and wear. The material is characterized by a high hardness and a high thermal conductivity.

**Ruby**

Synthetic ruby is monocrystalline alumina and gets its red color by the addition of some chromium oxide. It is biocompatible and very resistant to corrosion and wear. The material is characterized by a high hardness and a high thermal conductivity.

**Mineral wool**

This insulating material consists of glass or stone wool fibres and isolates in high oxidizing conditions and at high temperatures. Mineral wool is valid as commonly inert against organic solvents and acids.

**Glass, glass fibre, quartz, quartz glass**

These mineral materials are resistant against corrosion and wear and are mostly chemical inert. They are compatible with oils, fats and solvents and show a high resistance against acids and lyes up to pH values of 3 - 9. Concentrated acids (especially hydrofluoric acid) may embrittle and corrode the minerals. Lyes may ablate the surfaces slowly.

## 12.4 Metals

**Stainless steel**

Stainless steel is, apart from PEEK, the standard material in HPLC. Steels with WNr. 1.4404 (316L) are used, or with a mixture of higher compatibility.

They are inert against almost all solvents. Exceptions are biological applications which are metal ion sensitive, and applications with extreme corrosive conditions. These steels, in comparison to commonly used steels, are increasingly resistant against hydrochloric acid, cyanides and other halogen acids, chlorides and chlorinated solvents.

The use in ion chromatography is not recommended. In case of electrochemical applications, a passivation must be executed first.



**Hastelloy®-C**

This nickel-chrome-molybdenum alloy is extremely resistant to corrosion, especially against oxidizing, reducing and mixed solvents, even at high temperatures. This alloy may be used in combination with chlor, formic acid, acetic acid and saline solutions.

**Titanium, titanium alloy (TiAl<sub>6</sub>V<sub>4</sub>)**

Titanium has a low weight and a high hardness and stability. It stands out due to its very high chemical compatibility and biocompatibility. Titan is applied when neither stainless steel nor PEEK are usable.



	Created	Reviewed	Approved
Function	Technical Editor	Engineering	Head of Quality
Name	Anna Erben	Paul Pietsch	Kate Monk
Date	23/02/2023	23/02/2023	23/02/2023
Signature			 <small>Kathryn Monks (Paul, 2023 15:21 GMT+1)</small>

**0. Customer approval**

Prior to installation at the customer site, the customer has reviewed the OQ document and agrees with the design and scope.

Company name:

Name	Function	Reviewed & approved	Date	Signature

## Installation Qualification (IQ) for a Device

### 1. Definition of the Installation Qualification

The qualification document „Installation Qualification (IQ)“ is part of the quality management system at the company KNAUER Wissenschaftliche Geräte GmbH.

### 2. Scope

The customer can request the Installation Qualification. In case of a request, the technical support of KNAUER or a provider authorized by KNAUER performs this functionality test during the installation. The IQ is a standardized document and includes the following:

- Confirmation of flawless condition at delivery
- Check if the delivery is complete
- Certification on the functionality of the device

### 3. Instructions

All deviations from the specifications that occurred during installation have to be recorded in this document.

In addition, all measures taken to eliminate the deviations have to be noted down as comments in the list of rectifications (LOR) on page 4.

If certain items in the report are not applicable, this has to be indicated in the table as „N/A“ (not applicable). Major sections that are not used have to be crossed out (diagonal line), marked „N/A“, dated and signed.

All required documents have to be completed by the end of the installation. The document has to be reviewed and approved by an authorized person. The review and approval have to be documented with signature and date (DD/MM/YYYY).

The tests have to be carried out in a suitable environment, as described in the user instruction of the device.

### 4. About this document

The information in this document is subject to change without prior notice. This document may not be used, reproduced or translated without written consent of KNAUER Wissenschaftliche Geräte GmbH. Depending on the customer's quality assurance system, the signed document either has to be filed in the device folder or scanned and stored in an electronic archive.

### 5. Device data

Device name		Product number	
Serial number		Order number	
Firmware version			
Installation location			

### 6. Customer and manufacturer data

	Customer	Manufacturer
Company		KNAUER Wissenschaftliche Geräte GmbH
Customer number		-
Contact person/agent		
Address		Hegauer Weg 38
Postal Code/City		14163 Berlin
Phone		+49 30 80 97 27 111
E-Mail		support@knauer.net

## Installation Qualification (IQ) for a Device

### 7. Installation Qualification Tests

Test	Description	Specification	Passed	Failed	N/A	Comment/LOR No.
1	Identify the device.	The name on the device matches the name on the delivery order.				
2	Check the device for transport damage.	No transport damage is observed.				
3	Check the scope of delivery.	The scope of delivery matches the packing list and/or the delivery order.				
4	Check that the technical documentation provided is correct and complete (material documentation of wetted parts, calibration certificates etc.)	The documentation is correct and complete.				
5	Check that all equipment is properly and correctly labeled according to the delivery order and/or the labeling specifications document, if applicable.	The equipment is labeled correctly.				
6	Connect all loose parts (e.g. capillaries, tubings, measuring head) according to the user instructions.	The device is fully assembled and ready to use.				
7	Ensure that the installation site is suitable according to the user instructions.	The installation site matches the specifications in the user instructions.				
8	Connect the device to the power supply and switch it on.	The device starts (operating noise). The power LED or the display lights up.				

## Installation Qualification (IQ) for a Device

### 8. List of rectifications (LOR)

LOR No.	Test No.	Type of deviation*	Description of the deviation	Action plan	Persons responsible	Due date	Date/signature

\*Type of deviation:

A = acceptable (e.g. not a GMP-critical deviation)

N = not acceptable

Continuation of qualification activities into the next qualification phase is only possible when deviation is rectified.

T = temporarily acceptable

a) Release and use of the system is possible, even when the deviation is not rectified.

b) A continuation of qualification activities into the next qualification phase is possible, even when the deviation is not rectified

## Installation Qualification (IQ) for a Device

### 9. List of changes to the document

Revision no.	Description of change	Additional information	Date/signature

## Installation Qualification (IQ) for a Device

### 10. Certificate and approval

A KNAUER employee or an employee authorized by KNAUER has checked the device and performed all tests described in the IQ.

The IQ form has to be signed by an authorized person. The scope of the IQ meets the customer's requirements.

The results of the IQ, any changes made as well as the IQ process have been documented in this form in writing. The users listed below were instructed and are familiar with how to operate the device. Both parties confirm that the IQ has been performed to the customer's satisfaction by signing it.

#### 10.1 Customer approval

Name	Function	Date	Signature

#### 10.2 KNAUER agent approval

Name	Function	Date	Signature

### 11. Comments / recommendations

---

---

---

### Installation Qualification (IQ) for a Device

Appendix: List of supporting documents

No.	Test no.	Description

Science with Passion



Latest KNAUER instructions online:  
[www.knauer.net/library](http://www.knauer.net/library)

**KNAUER**  
Wissenschaftliche Geräte GmbH  
Hegauer Weg 38  
14163 Berlin

Phone: +49 30 809727-0  
Fax: +49 30 8015010  
E-mail: [info@knauer.net](mailto:info@knauer.net)  
Internet: [www.knauer.net](http://www.knauer.net)